

Cylinder Stretch as a Source of Vibration in Reciprocating Compressors

Brian C. Howes, M.Sc., P. Eng.

Kelly N. Eberle, B.Sc.

Val Zacharias, M.A.

Beta Machinery Analysis Ltd., Beta Monitors & Controls Ltd.

300, 1615 – 10th Ave. S.W.

Calgary, Alberta, Canada

T3C 0J7

Abstract

Vibration problems on reciprocating compressor pulsation dampeners and piping systems have several causes, such as pressure pulsation induced unbalanced forces, and forces and moments from the reciprocating and rotating components in the machine. However, an additional cause of vibration problems on the vessels and piping in close proximity to a compressor cylinder is cylinder stretch, that is, the elongation of the cylinder assembly, due to the gas forces generated by the internal pressures in the compressor cylinder. Case histories are presented which illustrate observed vibration problems due to cylinder stretch excitation and solution implemented to reduce vibrations.

Keywords

Compressor vibration; cylinder motion; cylinder stretch; design guidelines; modelling of compressors; vibration; reciprocating compressors.

Introduction

Twenty-five years of vibration trouble-shooting of reciprocating compressors, together with the analysis of almost 500 compressor installations at the design stage, has shown that conventional analyses of reciprocating compressors in the design stage are not always sufficient. While many potential problems are prevented, others may appear. For example, a phenomenon called cylinder stretch often causes excessive vibration. This paper analyzes cylinder stretch and provides case histories which illustrate it. Field measurements and modelling predictions are compared, and solutions are provided.

Vibration of vessels and piping attached to reciprocating compressor cylinders often results in high stress levels in the vessels and piping. If high enough, these stress levels will lead to failure. The cost of such failures can be significant, not only in terms of repair costs but also in safety and lost production time. Therefore, it is important to understand the sources of vibration in the design of the piping systems.

Description of Problem

General Definitions

The terms and examples given here refer to reciprocating compressors used in natural gas production but can generally be applied to any reciprocating machinery application. Shown in Figure 1 is a schematic drawing of a typical reciprocating compressor in a section view. The typical elements include the compressor frame, crosshead and crosshead guide, distance piece, piston, and cylinder. The cylinder crosshead guide and distance piece will be referred to collectively as the cylinder assembly. The compressor cylinder is designed to be double acting, that is, it can compress gas on both the head or outer end and crank or frame end of the cylinder. Changing the loading of the cylinder is usually accomplished by increasing the clearance volume at the head end of the cylinder, or by removing valves from the cylinder. Attached to the top and bottom of cylinder are the suction and discharge pressure pulsation dampeners.

The direction of vibration is described as either horizontal, axial, or vertical, with respect to the compressor. A horizontal vibration refers to vibration in the direction of piston motion. The axial direction is parallel to the centre line of the compressor crankshaft.

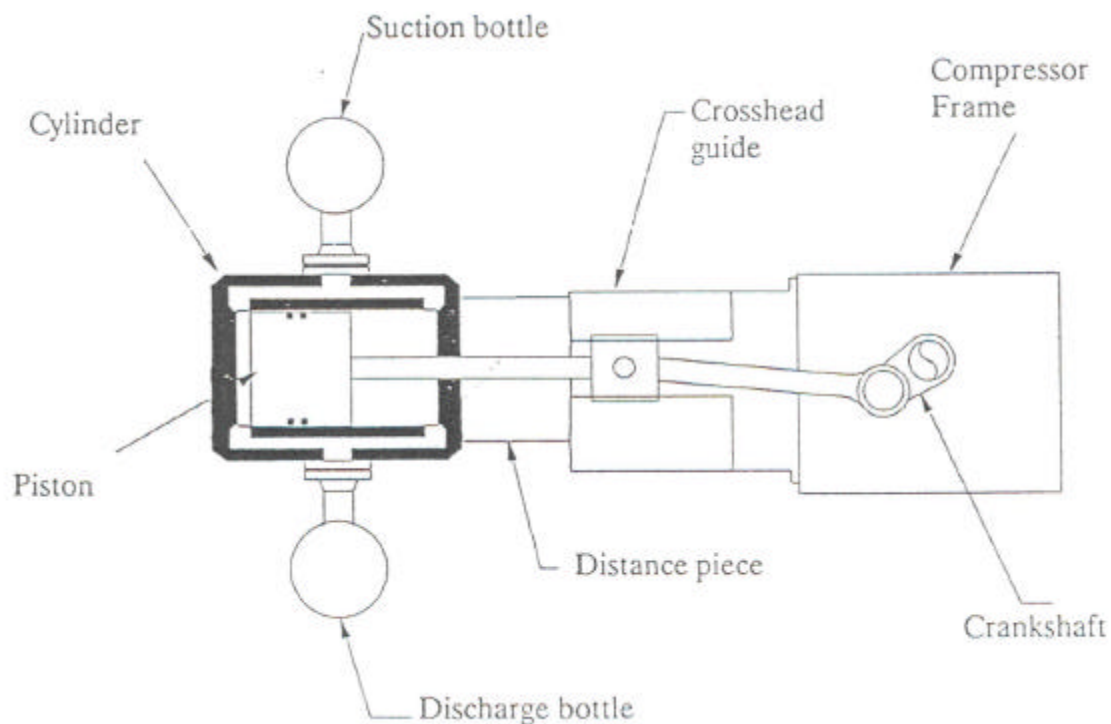

Figure 1. Section view, typical reciprocating compressor.

Definition of Cylinder Stretch

Cylinder stretch refers to cylinder motion in the horizontal direction. This motion is generated by the pressures inside the compressor cylinder. During each stroke of the piston, gas is compressed on first the head end and then the crank end of the piston. A corresponding pressure also acts on the cylinder during each stroke. This pressure results in an alternating force acting on the compressor cylinder. These forces cause the cylinder assembly to lengthen

and shorten during each stroke. This lengthening and shortening is referred to as cylinder stretch. Refer to Figure 2 and 3 for typical plots of cylinder pressure and rod load versus crank angle.

Cylinder stretch results in vibration of the piping system, which is analogous to vibration of a building due to an earthquake. A single vibration source, in this case at the connection of the pulsation dampener to the cylinder, results in vibration of the attached vessels and piping. When the magnitude of the source vibration is high enough, or the frequency of the source vibration is equal to the resonant frequency of the attached piping, excessive vibration results and failures can occur. Reducing the vibration levels involves reducing the strength of the vibration source, which is often difficult, or changing the piping system or its support to reduce the response.

Axial and vertical vibrations of the cylinder can also result in failures of the attached vessels and piping. These are different problems and will not be considered in this discussion.

Note that cylinder stretch is inherent in the compressor. Steps can be taken to minimize the cylinder stretch in the compressor design or the loading of the cylinders. However, cylinder stretch and its resultant vibration will always be present to some extent. Therefore, it is prudent to analyze the response of the attached vessels and piping to this source of vibration when designing the installation.

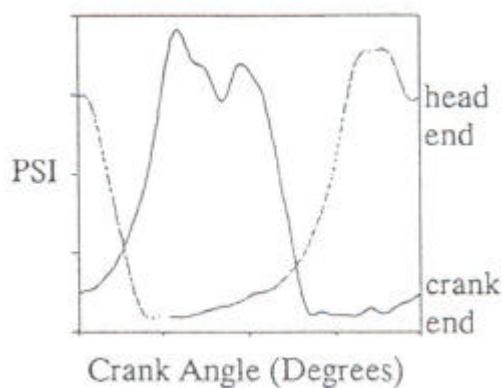

Figure 2. Cylinder pressure versus crank angle.

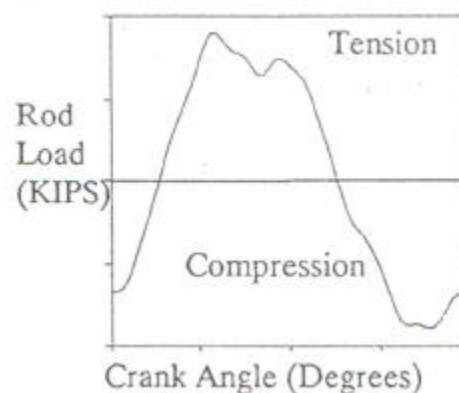

Figure 3. Rod load versus crank angle.

Associated Spectra

Force Spectrum of Gas Rod Load

A typical spectrum of the gas rod load forces, as taken from the rod load versus crank angle plot given in Figure 3, is shown in Figure 4. Note that the highest forces are typically below 7 or 8 times compressor run speed. The force level after the 8th order of run speed is generally very low. However, the magnitude of the gas forces at high frequencies can be affected by valve plate resonances, which can cause pressure oscillations which can result in higher than normal gas forces.

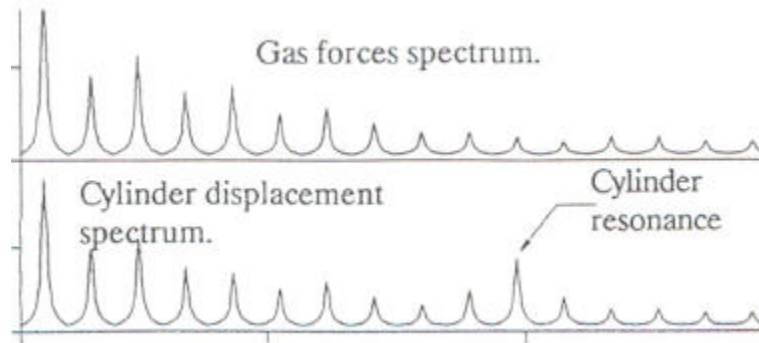

Figure 4. Gas forces and cylinder stretch vs frequency.

Cylinder Stretch Spectrum

A typical spectrum of the cylinder stretch or cylinder vibration in the horizontal direction is given in Figure 4. The magnitude of the cylinder stretch generally follows the force spectrum. The highest cylinder stretch occurs at frequencies up to 7 or 8 times compressor run speed in this example.

Note that at 11 X run speed, cylinder displacement is much higher than at adjacent harmonics, even though the corresponding cylinder gas force is no different. This higher response indicates the mechanical natural frequency of the cylinder assembly in the horizontal direction.

Mechanical Design Guidelines

Conventional Guidelines

A conventional guideline states that mechanical natural frequencies of piping and vessels near the compressor must be above twice maximum compressor run speed. The purpose of this guideline is to avoid resonance of these mechanical natural frequencies with the shaking forces at one and two times run speed. this is a necessary *but sufficient* guideline.

Expanded Guidelines

Analyze Higher Harmonics

Since considerable vibration can be generated above the second harmonic, both from cylinder stretch (as shown in Figure 4) and from pulsation induced unbalanced forces, analysis at the design stage must include frequencies above twice compressor speed.

Analyze Phasing Effects on Multi-Cylinder Dampeners

When a pulsation dampener is attached to two or more cylinders, the phasing between the throws of the crankshaft will cause the two cylinder stretches to vectorially add, depending upon the order of compressor speed.

Consider the example of a compressor which has two cylinders and a common pulsation dampener. If the phasing between the throws is 90 degrees, the cylinder stretch forces will also be 90 degrees apart at one times compressor run speed. However, the phasing between the cylinder vibration will be 180 degrees at two times run speed, 270 at 3 times, 360 or 0 at 4 times

and so on. High vibrations can result at a mechanical natural frequency above twice run speed, if the piping vibration mode is susceptible to a cylinder stretch phasing of 0, 90, or 180 degrees.

Analyze Response at All Operating Conditions

Cylinder loading affects cylinder stretch. Changing from double acting to single acting will tend to increase cylinder stretch at odd integers of run speed and decrease cylinder stretch at even integers. In the single-acting case, having a mechanical natural frequency at 3 times compressor run speed may result in excessive vibration, whereas a mechanical natural frequency at 4 times would be acceptable. In general, the double-acting case is easier to solve than the single-acting one.

Typical Solutions To Cylinder Stretch Problems

Altering Cylinder Loading

One solution to cylinder stretch vibration problems is to load the cylinder so as to minimize the cylinder gas forces, or for multiple cylinder cases, the vector sum of the gas forces. This approach is not always practical since specific operating conditions are often required.

Changing The System Mechanical Natural Frequencies

Piping vibrations are typically found to be highest at mechanical natural frequencies of the piping system. Vibration can be reduced by shifting the mechanical natural frequency to a frequency where the cylinder stretch is less. In the case of multiple cylinder pulsation dampeners, shifting the mechanical natural frequency to an order of run speed with different phasing can reduce vibrations.

The mechanical natural frequency of the system can be altered by changing the mass, mass distribution, or stiffness of the system. The mass of the system is increased by adding a weight to the piping or vessels. Distribution of the mass can be changed by moving a flange set located at the top of a pipe riser down to the level of a support. Stiffness can be changed by adding or removing braces or supports, or by changing pipe diameters. The mechanical natural frequency can also be changed by altering the pipe or vessel layout. These changes are least expensive in the design stage.

Increasing The System Damping

Vibration at resonance can be reduced by increasing the system damping. Methods of increasing damping include installing shock absorbers or using a constrained layer damping treatment (1,2). Designing and installing these damping devices is often difficult and costly. Maintenance is required because of degradation due to normal wear and operation in harsh environments.

Modify The System Mode Shape

The mode shape of a structure is defined as the displaced shape of the structure as it vibrates. Each natural frequency has a distinct mode shape. Each mode shape consists of at least one point with no movement, referred to as a node point, and at least one point with maximum movement, referred to as an antinode.

Consider the example of a cantilever beam vibrating at its second mechanical natural frequency (or second mode) as shown in Figure 5. Points A and C represent antinodes on the mode shape and point B represents the node of the mode shape. (Refer to Thomson² or Henderson¹ for a further definition of these terms.)

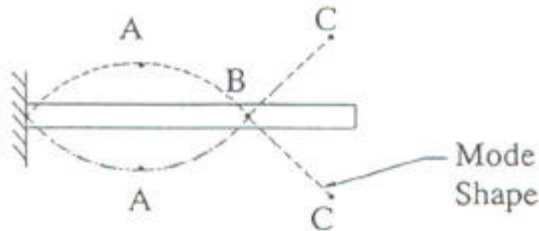

Figure 5. Vibration on a cantilever beam.

Moving the node point of the mode shape closer to the source of the vibration results in reduced vibrations, since force on the node point does not excite vibration in that mode. Changing the mass and/or stiffness of the system is required to change the mode shape.

Additional Considerations in Cylinder Stretch Problem Solutions

Any solutions must be considered not only for their effect on cylinder stretch vibration, but also for their effect on the system response to other vibration sources. For example, lowering a mechanical natural frequency out of the range of 3 times run speed to avoid a cylinder stretch vibration may create a new vibration problem due to high residual unbalanced moments from the compressor at two times run speed.

Case Histories

Method

In the first case history, two models were analyzed. These included:

- a digital computer model of the acoustical pulsations and the resultant unbalanced forces, and
- a finite element model of each system.

Each model included the suction piping, suction bottle and compressor cylinder. In the second case, an acoustical model was not required because the direction of vibration precluded pulsation induced unbalanced forces.

The cylinder gas forces were calculated for the compressor operating conditions and used in the model to predict the response due to cylinder stretch. The modal damping used in the finite element model was determined from field measurements.

Case 1: Cylinder Stretch Vibration in a One Cylinder Bottle

Background

The system consists of a motor driven 4 throw, 3 stage separable reciprocating compressor. The compressor operates in natural gas services with typical suction and final discharge pressures of 110 and 1140 psig. The operating speed range was 650 to 900 RPM. Both the second and third stage suction bottle were attached to one cylinder on the same side of the compressor. Phasing between the two cylinders was 90 degrees at one times compressor run speed.

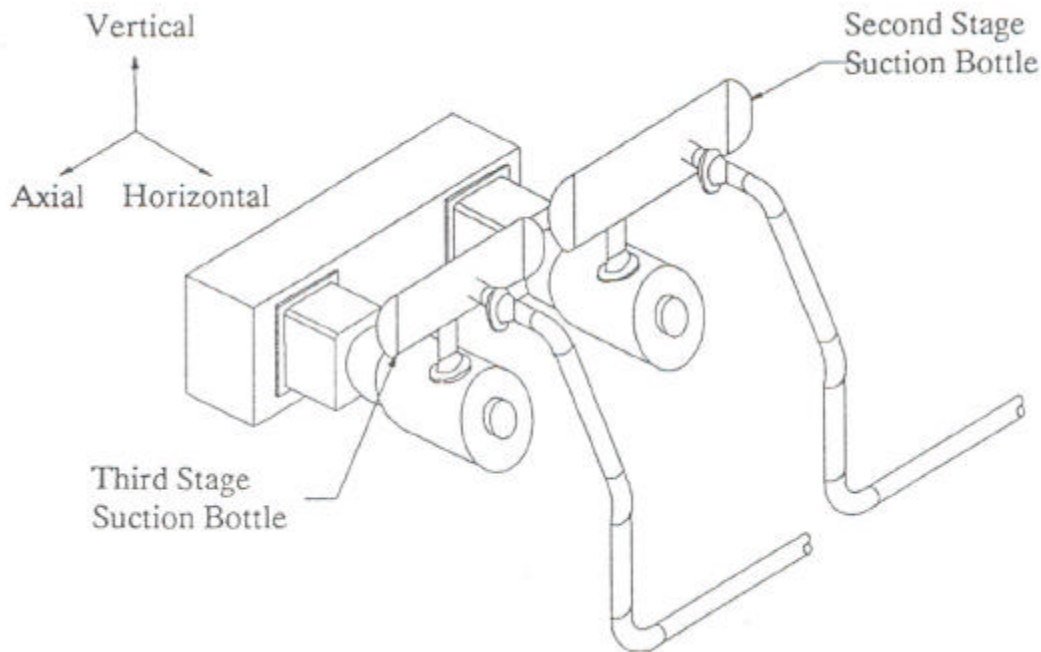

Figure 6. Compressor layout, Case 1.

The operator noted high vibration on the second and third stage suction bottles and on the suction piping into the bottle. See Figure 6 for sketch of system.

Field Measurement

Maximum vibrations measured on the second stage suction bottle were 7 mil p-p at 41.6 Hz and 12 mil p-p at 52.0 Hz. The third stage suction bottle and piping had maximum vibration of 12 mil p-p at 38.4 Hz and 6.5 mil p-p at 55.2 Hz. Pressure pulsations recorded at several locations were within guidelines.

Analysis

The pipe and bottle vibration was attributed to cylinder stretch, based on the vibration mode shape and magnitude of the cylinder gas forces. Low system damping was a contributing factor.

Mechanical natural frequencies of 42.7 Hz and 50.0 Hz were predicted for the second stage system and 35.0 Hz and 53.4 Hz for the third stage system. Vibration levels of 7.3 mil p-p at 42.7 Hz and 11.2 mil p-p at 50 Hz were predicted for the second stage system and 10.8 mil p-p at 35.0 Hz and 6.2 mil p-p at 53.4 Hz for the third stage system.

These predictions agreed closely with the measured vibrations.

Several modifications were analyzed to determine a method of reducing the vibration. These modifications included

- increasing the stiffness of the cylinder nozzles
- changing the pipe layout
- adding bracing to the piping
- clamping the ends of the two suction bottles together, and
- redesigning the bottle and pipe layout.

After consulting the compressor operator, recommendations were agreed upon which predicted the reduction of vibrations to guidelines. The final modifications included:

- stiffening the cylinder nozzle on the second stage suction bottle
- bracing the second and third stage suction risers, and
- clamping the ends of the suction bottles together.

Clamping the suction bottles together was done by installing a flat bar clamp around each bottle and bolting braces between tabs on each of the clamps. Damping material was installed between the clamp and shell of each bottle to prevent wear on the shell as well as to add damping to the system.

Results

After the modifications had been installed, vibration on the second and third stage suction bottle and piping was acceptable.

Conducting a cylinder stretch analysis in the design stage would have predicted these vibration problems. Changes in the bottle design and system layout could have been implemented at that time. The repair cost, and the use of braces which limit access, would thus have been avoided.

Case 2: Cylinder Stretch Vibration in a Three Cylinder Bottle

Background

The system consists of a motor driven 6 throw, 2 stage separable reciprocating compressor. The compressor operates in natural gas service with typical suction and final discharge pressure of 200 and 850 psig. The operating speed range is 600 to 900 RPM. The second stage suction bottle is common to three cylinders on one side of the compressor. Phasing between cylinders 2, 4, and 6, is 0, 120, and 240 degrees at one times compressor run speed. See Figure 7.

The operator was concerned with high vibration on the second stage suction bottle and the suction piping into the bottle.

Field Measurement

Maximum vibration of 5.0 in/s pk at 42.5 Hz was recorded on the inlet nozzle into the suction bottle in the horizontal direction. Mechanical natural frequencies of the bottle and the riser into the bottle in the horizontal direction were found to be 42.5 Hz and 69.3 Hz. The 42.5 Hz mode shape was a translation mode of the bottle and suction piping in the horizontal direction. Pressure pulsations recorded at several locations were within guidelines.

Analysis

Cylinder stretch was suspected to be the cause of the pip and bottle vibration, based on the vibration mode shape and the phasing of the cylinders. The horizontal translation mode of the bottle and piping was particularly susceptible to cylinder stretch since all 3 cylinders are in-phase at 3 times compressor run speed.

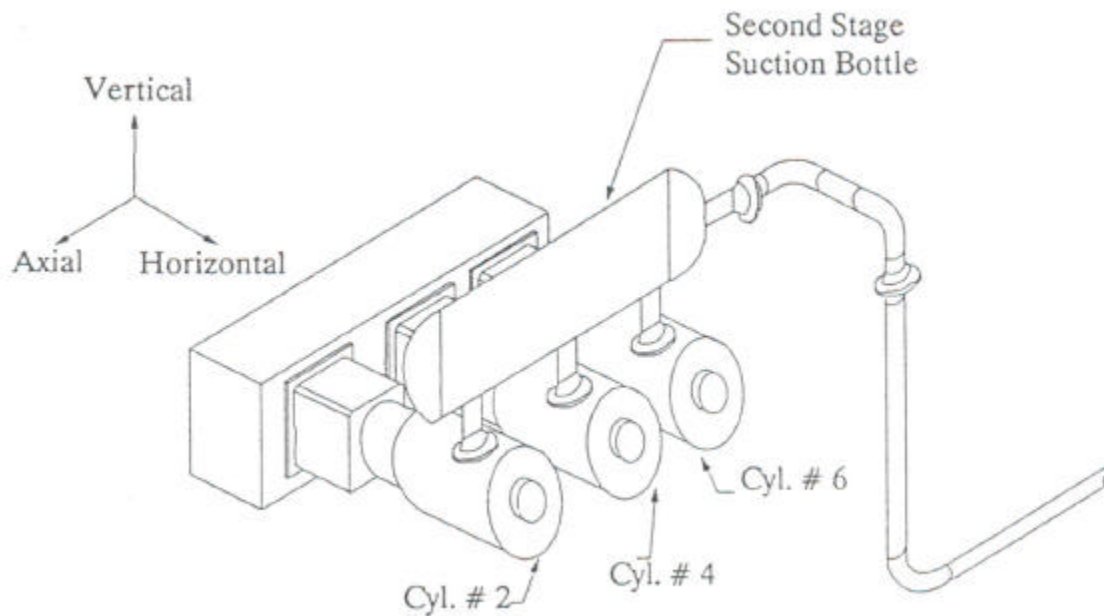

Figure 7. Compressor layout, Case 2.

Mechanical natural frequencies of 42.1 Hz and 71.8 Hz were predicted by the model. Maximum vibration of 4.3 in/s pk at 42.1 Hz was predicted on the suction bottle inlet nozzle due to cylinder stretch. These predictions agreed closely with the as-found vibrations and mechanical natural frequencies.

Several modifications were analyzed to determine a method of reducing the vibration. These modifications included:

- adding bracing to the piping and
- changing the pipe layout between the suction bottle and scrubber.

The one change which both reduced the vibration to acceptable levels and met the requirements of the compressor operator was changing the pipe layout between the suction bottle and scrubber. Maximum vibration 0.8 in/s pk at 64.3 Hz was predicted for this new layout.

Results

After the new pipe spool piece was installed, maximum vibration of 0.7 in/s pk at 63.0 Hz was recorded. The measured vibration compares closely to predicted levels.

Analysis of the cylinder stretch response in the design stage would have indicated this vibration problem.

Conclusions

Cylinder stretch may generate vibration problems in the piping and vessels attached to reciprocating compressor cylinders. These problems can be avoided in the design stage by modelling the forced response of the piping due to cylinder stretch. This analysis must include frequencies above two times run speed.

This analysis may also benefit other reciprocating machines, such as Diesel engines and pumps.

References

1. Henderson, J.P., Jones, D.I., Nashif, A.D. Vibration Damping. New York, John Wiley and Sons, 1985.
2. Thomson, W.T. Theory of Vibration with Applications, 2nd Edition. Englewood Cliffs, New Jersey, Prentice-Hall Inc., 1971.