



Design Challenges for Reciprocating Compressors in Specialty Gas Services

by:

Kelly Eberle and Michael Cyca

Engineering Design

Beta Machinery Analysis

Calgary, AB

Canada

keberle@betamachinery.com mcyca@betamachinery.com

GMC 2010

October 4 – 6, 2010

Abstract:

Many software tools are used to simulate compressor performance and pressure pulsations in piping systems. Designers of reciprocating equipment rely on these tools to accurately simulate gas properties and pressure pulsations for specialty gases. Two case studies on reciprocating compressors, involving ethane and ethylene, outline the root causes and consequences of inaccurate performance and pulsation predictions. Both systems experienced many problems after commissioning. Field analysis and subsequent simulation found inaccuracies in compressor performance modeling.

This paper outlines a number of design tips and “lessons learned” that will be helpful to engineers involved in all reciprocating compressor applications.

1 Introduction

Computer models are used to simulate many different aspects of the operation of reciprocating compressors. Typical applications of computer models include simulating the compressor performance, torsional and lateral responses, deflection and stress in the skid beams due to lifting, dynamic response of the compressor cylinders, bottles and piping, and thermal expansion of the piping. Modeling of the compressor systems requires representing the physical properties of the compressor, vessels, piping and gas. The physical properties of the compressor, vessels, and piping are well defined. The physical properties of the gas are determined by testing and thermodynamic theory. Many different mathematical models exist for calculating gas properties. Each of these models has various strengths and weaknesses in terms of the accuracy with which they represent the gas physical properties. Mathematical models have been developed, which are well known and have been proven to accurately simulate common gases such as natural gas in pipeline applications. Compressors operating in a refinery or manufacturing facility are often used in applications where the gases are unique and simulation of the physical properties is not well understood. These specialty gases require proper selection of the model techniques to ensure that the results from the simulations result in a safe and reliable design.

Case studies will be presented to show the impact of incorrect modeling of gas properties. In the first case study, compressor performance simulation of an ethane service by many programs produce erroneous results. The second case study shows how inaccurate simulation of pressure pulsations leads to excessive vibrations on the compressor. Before discussing these case studies in detail, some background on compressor performance modeling, calculating gas properties, and pressure pulsation analysis in these applications is necessary.

2 Background

2.1 Compressor Performance Simulation and Equations of State

Simulating or modeling the performance of a reciprocating compressor involves calculating the expected flow, power consumption, discharge temperature, etc., based on the compressor geometry and operating information. The operating information typically includes inlet pressure, discharge pressure, inlet temperature, and gas composition. The gas composition and operating data is used to calculate thermodynamic properties of the gas; these properties are then used in the performance calculation. For example the adiabatic discharge temperature for the gas that is being compressed, T_D , can be calculated from the following equation.

$$T_D = T_S \cdot R^{\left(\frac{k-1}{k}\right)}$$

where

T_S = suction temperature (absolute)

R = compression ratio (absolute discharge pressure divided by absolute suction pressure)

k = ratio of specific heats

The ratio of specific heats is a physical, or thermodynamic characteristic, of the gas. There is no theoretical means of calculating characteristics such as the ratio of specific heats for gases. Typically, experimentation is done to determine these properties at a few temperatures and pressures and then models or equations of state (EoS) are derived. These equations of state can then be used to calculate the thermodynamic properties of gases for a range of pressures and temperatures. Many EoS have been developed, such as Van der Waals, Redlich-Kwong, Peng Robinson, Berthelot and Dieterici to name a few. All EoS have pressure and temperature ranges and gas mixtures where they are more accurate than others, so care must be taken to properly select the appropriate equation for the particular application.

Another factor that is important in the calculation of the gas properties is determining where the particular operating point is relative to the “critical point.” The critical point, also called a critical state, specifies the conditions (temperature and pressure) at which a phase boundary ceases to exist. It is extremely difficult to obtain the fluid properties at, or around, the critical point experimentally, or from EoS models. The other region where an EoS is inaccurate is at very high pressure, both above and below critical temperature, unless careful modifications to the EoS are made, as will be demonstrated later in a case study.

The image shown in Figure 1 is a representative pressure-temperature phase diagram for water. The calculation of the gas properties is relatively simple for a gas when the process remains within the gaseous phase and below the critical temperature and pressure. In some cases the gas process transitions from one area of the phase diagram to another requiring a more robust model of the gas properties.

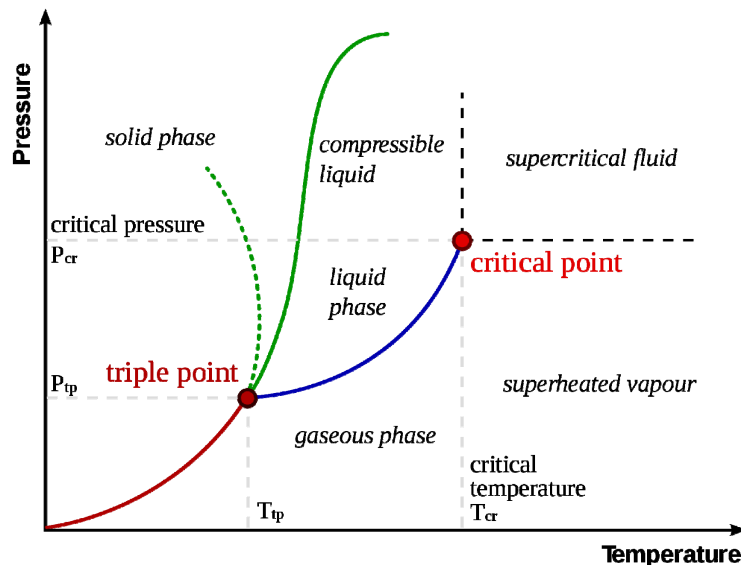

Figure 1: Typical Phase Diagram

The discharge temperature was cited earlier as one output from the compressor performance simulation that is dependent on accurate calculation of the gas properties. Other compressor performance results, such as, volumetric efficiency, flow, and power are dependent upon gas properties, such as, the compressibility, ratio of specific heats, polytropic exponent, viscosity, and specific gravity. Accurate calculation of these gas properties is key to accurate calculation of the compressor performance.

2.2 Pressure Pulsation Simulation

2.2.1 Gas Properties

The previous section described the importance of accurately simulating the gas properties when calculating compressor performance. Similarly, simulating pressure pulsations generated by reciprocating compressors involves many of the same aspects of simulating gas properties. One key parameter in the understanding of pressure pulsations in a reciprocating compressor system is the acoustic velocity, or speed of sound in the gas. The acoustic velocity, c , can be calculated using the following equation.

$$c = 30.87 \left(\frac{k \cdot T \cdot Z}{SG} \right)^{1/2} \quad (\text{SI units})$$
$$c = 41.42 \left(\frac{k \cdot T \cdot Z}{SG} \right)^{1/2} \quad (\text{Imperial units})$$

where

k = ratio of specific heats

T = absolute temperature (°K, or °R)

Z = compressibility

SG = specific gravity

The acoustic velocity in the gas is one of the most fundamental and critical characteristics calculated for a pulsation analysis. Other acoustical characteristics are also dependent on the gas properties. Accurate calculation of gas properties is key for an accurate pulsation analysis.

Note that the equations referenced above are simplified assuming the gas properties are constant with time. The fluctuating pressure and temperature in reciprocating compressors means the gas properties will also be time dependent. Typically these gas property dependencies on temperature are small but can be significant in some cases.

2.2.2 Pulsation Model

The mathematical model of the flow dynamics is as important as the calculation of the gas properties. There are different computer programs available for simulating pressure pulsations in reciprocating compressor installations. The programs fall into two basic groups. The first group is the first generation of programs that are based upon acoustic plane wave theory. These programs were developed in the 1970s and 80s to replace analog computers. These programs include many simplifying assumptions which allow for the acoustic equations to be solved in the frequency domain. Thus, they are called Frequency Domain, or FD, programs. The second generation of pressure pulsation simulation programs started to be developed during the 1990s. These programs used a more sophisticated model of the fluid dynamics and were able to consider nonlinearities and time varying boundary conditions at the compressor cylinder valves. These programs simulate the fluid dynamics in the time domain and are commonly referred to as TD programs. TD pulsation analysis programs are much more sophisticated than the older FD based programs, yielding more accurate results. Also, the TD programs are able to calculate characteristics like dynamic pressure drop, which cannot be accurately determined by FD based programs. The main drawback to TD programs is the longer solution times. Faster computer hardware and more advanced solvers are required.

The methodology used by the pulsation analysis program to analyze the reciprocating compressor system is also key to a successful design. Shaking forces are generated by

pressure pulsations coupled with the piping geometry. These forces must be minimized to ensure vibrations are acceptable. API 618 5th Edition^[1] includes guidelines for shaking forces from pressure pulsations on piping and pulsation bottles. However, there are other pulsation shaking forces that must be evaluated that are not yet included in API 618. One such force that Beta Machinery Analysis (Beta) has identified during many years of design and field experience is the shaking force acting between the pulsation bottle and the compressor cylinder, referred to as the cylinder shaking force. Figure 2 is a general arrangement drawing for a typical horizontal reciprocating compressor package showing this force. This shaking force is the result of the different pressure pulsation amplitudes and phases in the gas passage and pulsation bottle and has been shown to cause excessive vertical vibration on horizontal compressors^[2] and, in some extreme cases, has caused failure of head end cylinder supports. This shaking force can also result in high vibration in vertical compressors, as shown in Case Study 2.

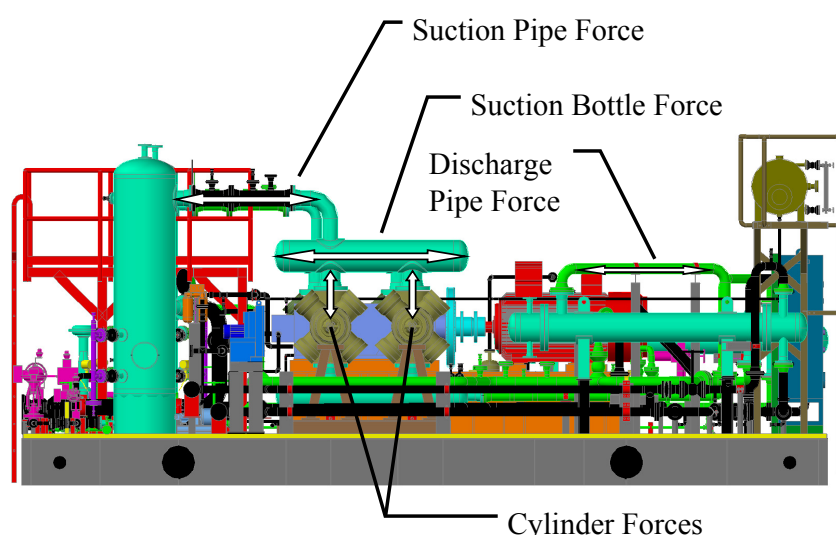

Figure 2: Some Shaking Forces in a Reciprocating Compressor Package

The following case studies show the effect of gas properties on the simulation of compressor performance and pulsation analysis.

3 Case Study 1

3.1 Background

This case study includes a 6 throw, two stage horizontal compressor in an ethane service. A plan and elevation view of the compressor package is shown in Figure 3. The compressor is driven by a 3900 kW (5200 HP) induction motor with a fixed full load speed of 885 rpm. Nominal suction and discharge pressures are 21.5 barg to 84 barg (413 to 1215 psig). The compressor package is relatively simple with scrubbers on the first and second stage suction. An interstage cooler is not required in this application as is typical for compressors in this type of application. The discharge temperatures are well within the allowable range of safe operation.

The gas in this service is 96% ethane, with the remainder of the gas being methane, propane, and iso-Butane, resulting in a specific gravity of 1.04.

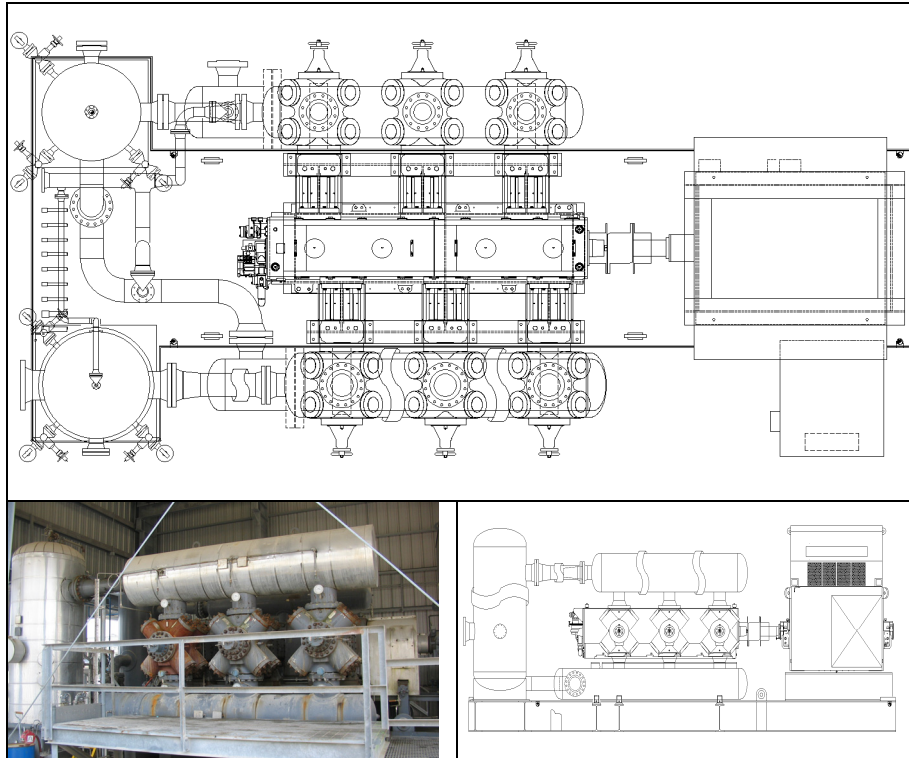

Figure 3: Compressor Plan and Elevation Views

Once the unit was in operation, the owner had noted that the compressor was not performing as expected. There was a noticeable difference in the flow and power requirement.

3.2 Investigation

The review of the performance calculations showed a significant difference between the calculated and measured temperature of the first stage discharge. A cursory review of the original performance calculations showed the expected first and second stage discharge temperatures were 26°C (79°F) and 54°C (129°F) compared to the observed temperatures of 51°C (124°F) and 88°C (191°F), a difference in the absolute temperature of 10%. The temperatures are measured at the cylinder nozzles and, hence, include the valve heating effects. A difference of 10% between a compressor performance model and observation is generally acceptable; however, in this case the error continues to be compounded as temperature is used in other calculations of compressor performance and gas properties and by the fact that there was no cooler. Further investigation showed other performance factors, such as, flow and power were significantly different, much higher than 10%, when the original performance calculations were compared to the observations.

Before the pulsation model could be investigated, the inaccuracies in the compressor performance model needed to be resolved. Additional performance calculations were done using a variety of OEM programs, commercial programs, and Beta's own compressor performance program. The different performance programs showed a wide variation in result. None of the OEM or commercial programs tested were able to accurately calculate the compressor performance. Several of the programs were not able to calculate the compressor performance for the two stage operation as the proper gas properties could not be calculated and the program was not able to achieve a mass balance for the first and second stage (the programs crashed or aborted due to errors). Beta's compressor performance program

calculated the first and second stage discharge temperatures to be 49°C (121°F) and 86°C (188°F), less than 1% difference between the calculated and measured absolute temperatures.

Figure 4 shows the difference between the discharge temperatures that were calculated by the various performance programs as compared to the observed discharge temperature. The discharge temperature is one of the fundamental characteristics of the compressor performance, which must be calculated accurately as it is used in many other calculations. Errors in the discharge temperature calculation will be compounded in later calculations resulting in greater errors.

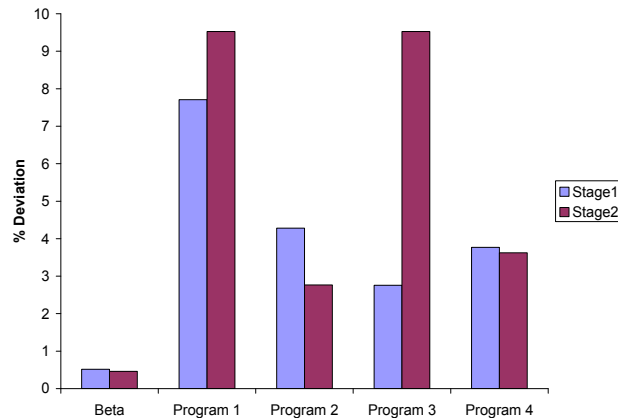

Figure 4: Percent Deviation in Calculated Absolute Discharge Temperature from Measured

The main reason for the variation in the discharge temperature calculated in this case is that the first stage discharge conditions were significantly above the critical pressure and temperature of the ethane phase diagram. Figure 5 shows a Mollier diagram for ethane with the first and second stage operating points shown. Additional corrections are required for ethane in this region to accurately calculate the gas properties used in the compressor performance.

Compressor valve loss calculations would also be inaccurate because of errors in thermodynamic property variations. This error would lead to inaccurate overall performance predictions for the compressor system. Careful consideration of the EoS and how it predicts pressure-volume-temperature relationships needs to be considered. As previously stated, inaccurate prediction of these relations would be carried over to all thermodynamic properties.

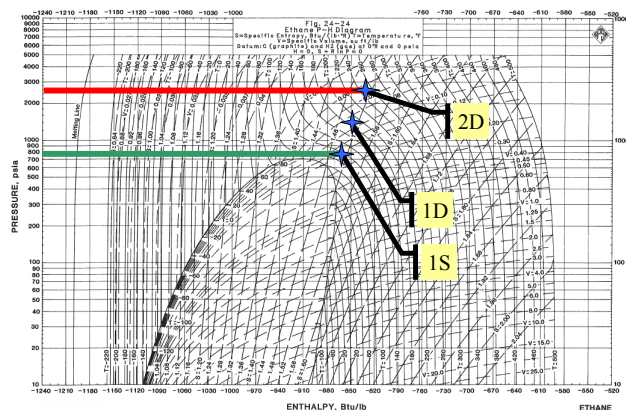

Figure 5: Mollier Chart^[3] Showing Two Stage Compression

3.3 Problem Resolution

A pulsation analysis of the compressor package was done with the initial, and incorrect, compressor performance. The original study resulted in pulsation bottles with baffles and choke tubes to create filters that controlled pulsations to very low levels. This design resulted in bottles being over conservative. Beta conducted a pulsation analysis with the more accurate compressor performance model. Results indicated the pulsation control was very conservative. A solution with lower pressure drop and HP losses could have been developed if the original pulsation study had been done with a more accurate compressor performance model.

4 Case Study 2

4.1 Background

This case study has a 4 throw, single stage vertical compressor in ethylene service, as shown in Figure 6. The compressor is driven by a 1250 kW (1650 HP) motor at 420 rpm. The nominal suction and discharge pressures are 23 barg (330 psig) and 63 barg (915 psig).

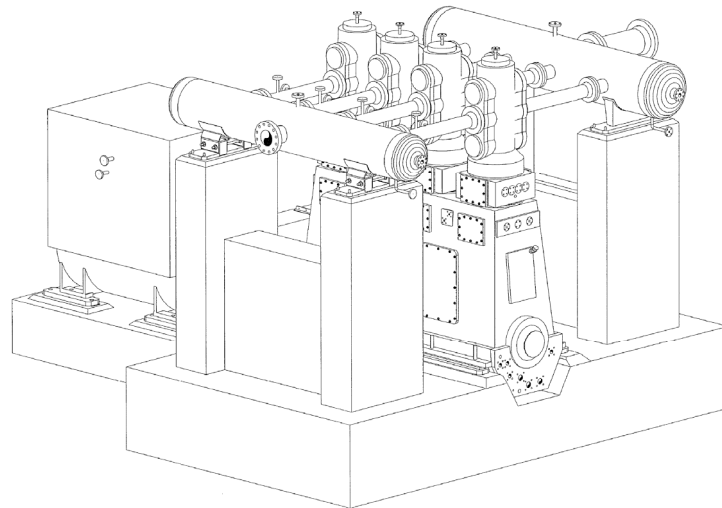

Figure 6: Isometric View of the Compressor Installation

At commissioning the compressor had several vibration problems on the piping and vessels. Many support modifications were implemented, which helped reduce vibrations. The compressor cylinder vibrations remained high and were increasing over time, such that the compressor was becoming unsafe to operate. Beta was contacted to determine causes and solutions.

4.2 Investigation

The evaluation began first with a review of the measurements and work previously conducted. A pulsation and mechanical analysis of the compressor installation had been conducted by another consultant prior to construction. Beta conducted site testing on the compressor to measure pressure pulsations, vibrations, and mechanical natural frequency measurements. Figure 7 shows an isometric of the piping system with test point locations.

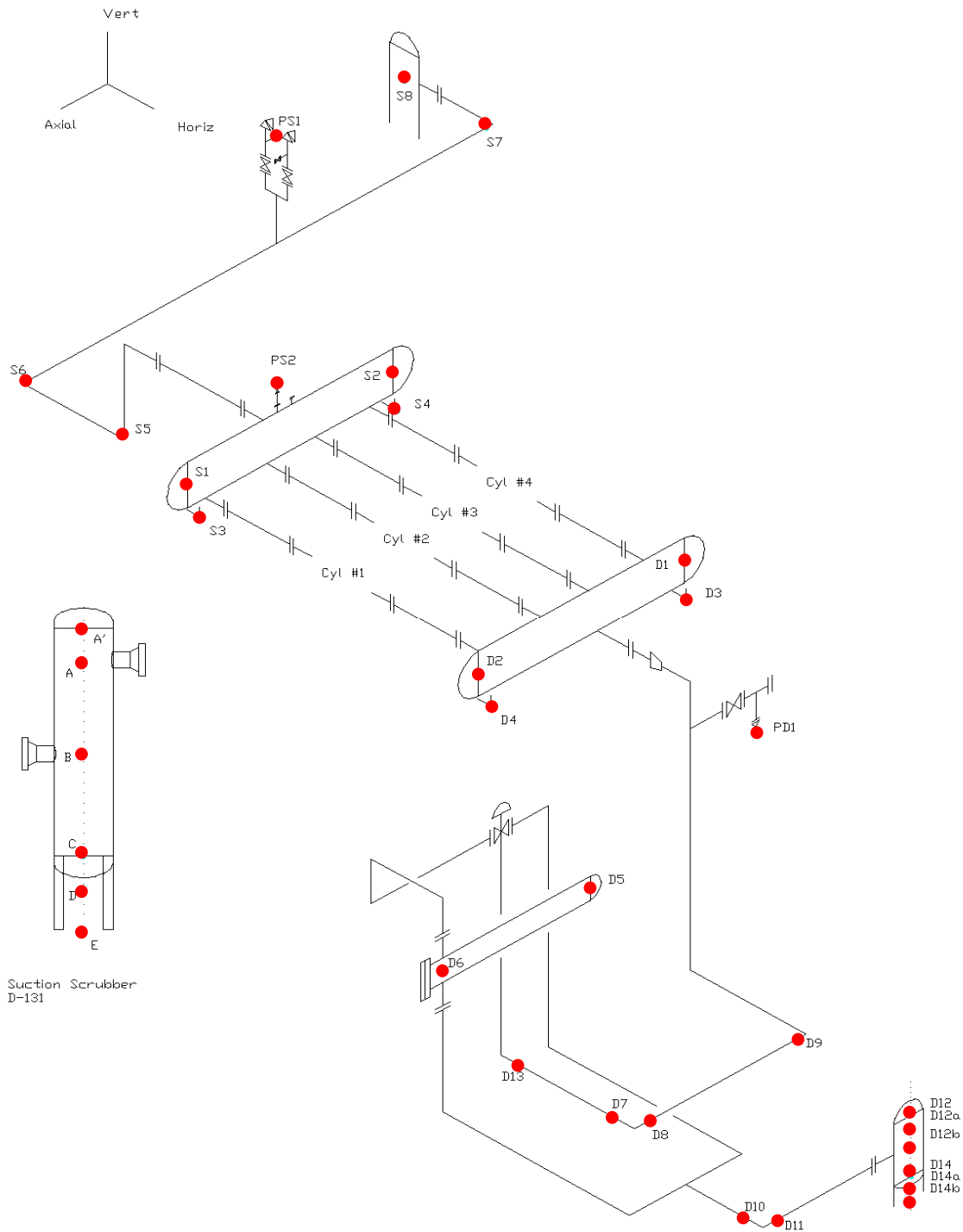

Figure 7: Test Point Locations

Vibration measurements showed the frequency of the highest vibration was at the 4th order of compressor speed, approximately 28 Hz. The direction of the highest vibration in the suction and discharge system was in the horizontal direction, that is, the direction perpendicular to the crankshaft axis. Figure 8 shows a sample of the vibrations measured on one of the compressor cylinders and the discharge piping. The cylinder and piping vibration is more than twice guideline levels.

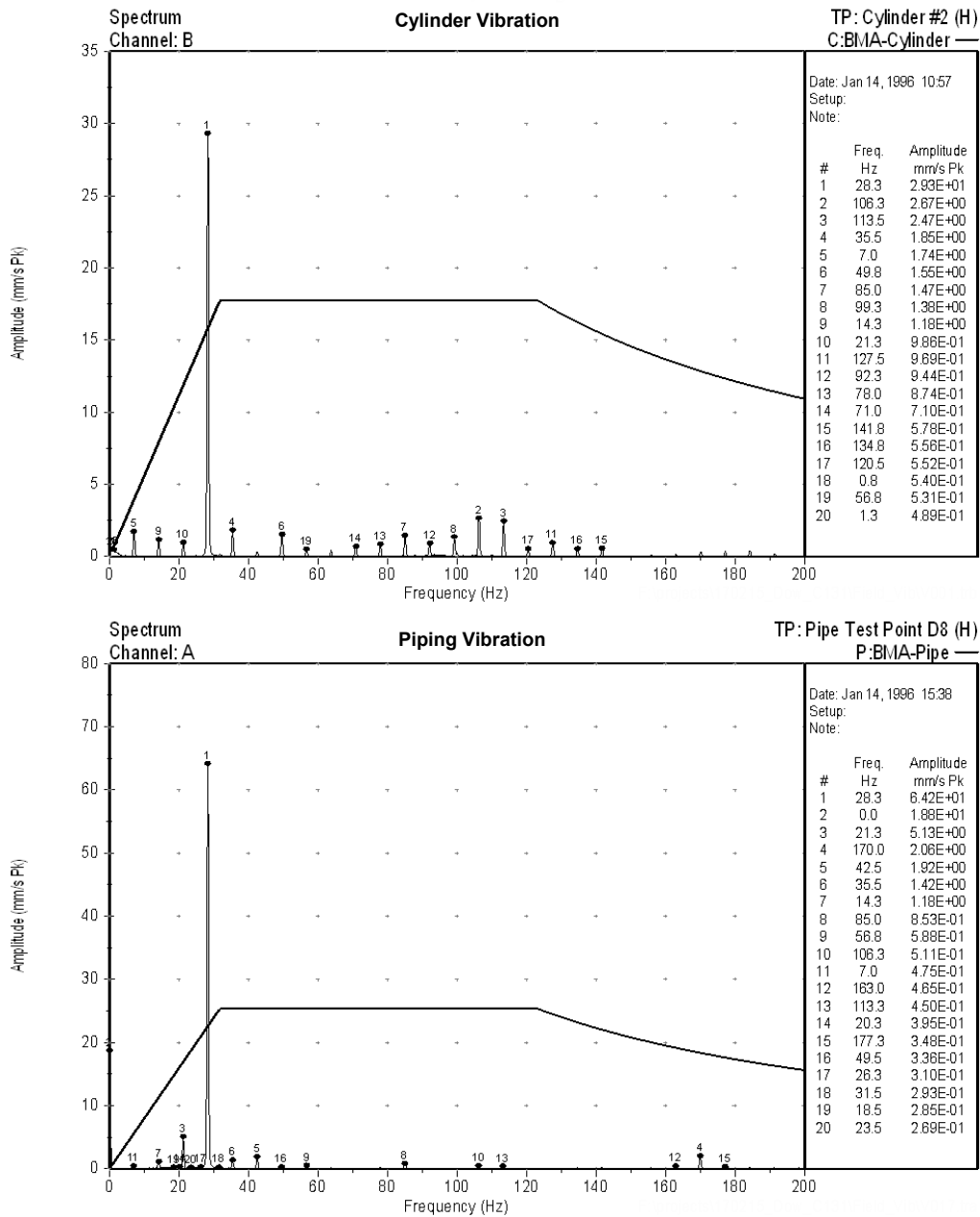

Figure 8: Sample Vibration Data

Pressure pulsations were measured at locations in the suction and discharge system. The pulsations were also highest at the 4th order of compressor speed. Pressure pulsations were more than twice API 618 guidelines at several locations. The results from the original pulsation analysis showed that pressure pulsations should be at or below API 618 guidelines. Note that the original pulsation study used FD pulsation software. This large discrepancy between measured and calculated pulsations raised concerns with the accuracy of the original pulsation analysis. To resolve this puzzle, a pulsation analysis was conducted using Beta's Time Domain software to assess the suction and discharge systems. Figures 9 and 10 show plots of the suction and discharge pulsation models.

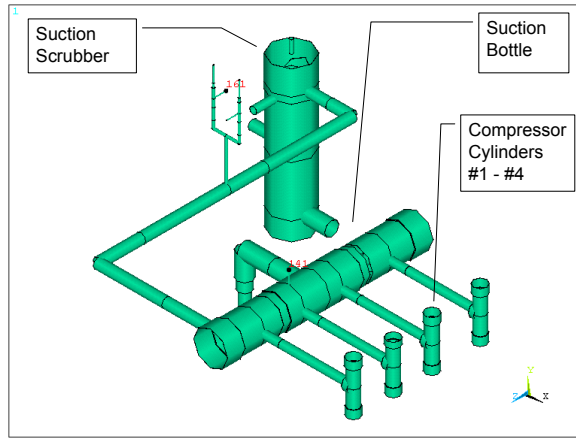

Figure 9: Suction System Pulsation Model

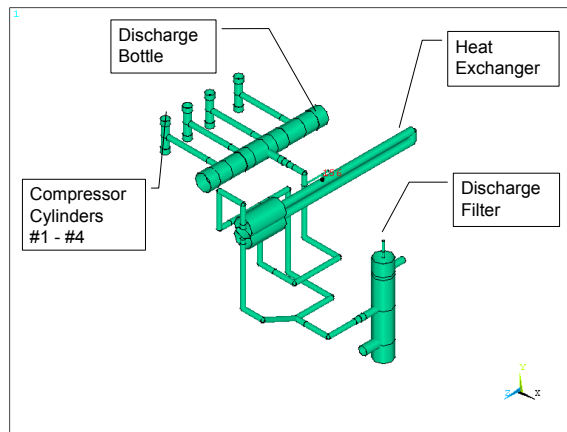

Figure 10: Discharge System Pulsation Model

Pressure pulsations calculated by the TD simulation were compared to measured pulsations as well as the pulsations calculated in the original pulsation model. These pulsation results are shown in Figure 11. The pressure pulsations from the TD simulation agree with the measurements of the actual system. Note that the pressure pulsations from the TD model are calculated for a speed range of $\pm 10\%$ of the compressor speed range. The actual compressor speed is fixed at 420 rpm, so there is only one measured pulsation value at each order of compressor run speed in the field data.

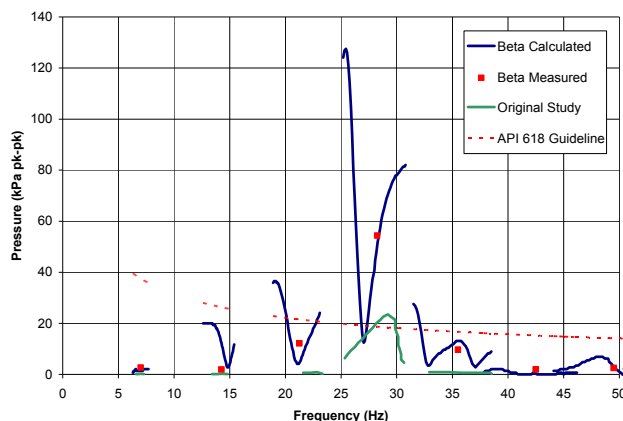

Figure 11: Calculated and Measured Pressure Pulsations

The pressure pulsations calculated by the original pulsation model are shown to be significantly less than the measured pulsations. The difference in the pulsations levels is, in part, due to the original study using a FD pulsation model. Beta also has a FD pulsation model and the simulation was rerun with it. The comparison between Beta's FD and TD models showed only a small difference in pulsation results. The remainder of error in the original pulsation study model is from the calculation of the gas properties. As shown later, the calculation of the acoustical velocity is key to accurately calculating pulsation in this case.

The suction and discharge pulsation models were then evaluated in more detail, since the measurements showed the TD model more accurately represented the gas properties and pulsation characteristics generated by the compressor. The shaking forces from pressure pulsations were generally found to be at low levels for the suction system in the piping upstream of the suction pulsation dampener (bottle) and downstream of the discharge pulsation dampener. A high shaking force was calculated between the compressor cylinders and the discharge bottle at the 4th order of compressor run speed. This force is the result of an acoustical resonance between the bottle and cylinder, as shown in Figure 12. A ¼ wave acoustical resonance sets up between the cylinder and bottle with high pulsations at the compressor cylinders and low pulsations at the bottle. The relatively long spool piece between the cylinder and bottle, and the properties of the gas at the discharge operating conditions, results in this resonance and, in addition, a high horizontal force acting on the compressor cylinders and bottle, as illustrated in Figure 13. Note that this shaking force was not calculated as part of the original pulsation study.

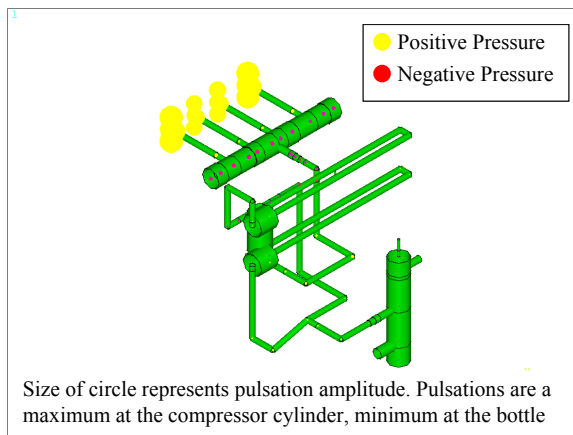

Figure 12: Pulsation Operating Deflected Shape Plot showing resonance between cylinder and bottle

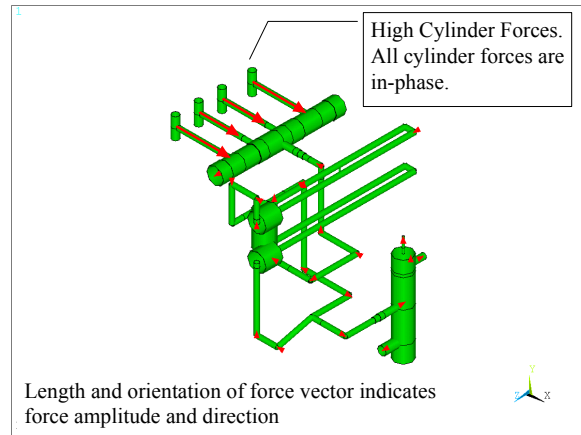

Figure 13: Discharge system forces at 4th order of compressor speed

Figure 14 shows spectrum plots of the discharge system cylinder horizontal forces. The forces acting on cylinders #2 and #3 are slightly lower than #1 and #4 because of the configuration of the internals in the pulsation bottle. In the 1990s, Beta developed a field tested and proven cylinder nozzle force guideline. The amplitude of the cylinder forces at the 4th order of compressor speed are approximately twice Beta's cylinder nozzle force guideline. Note that API 618 does not recognize or include a guideline for this force.

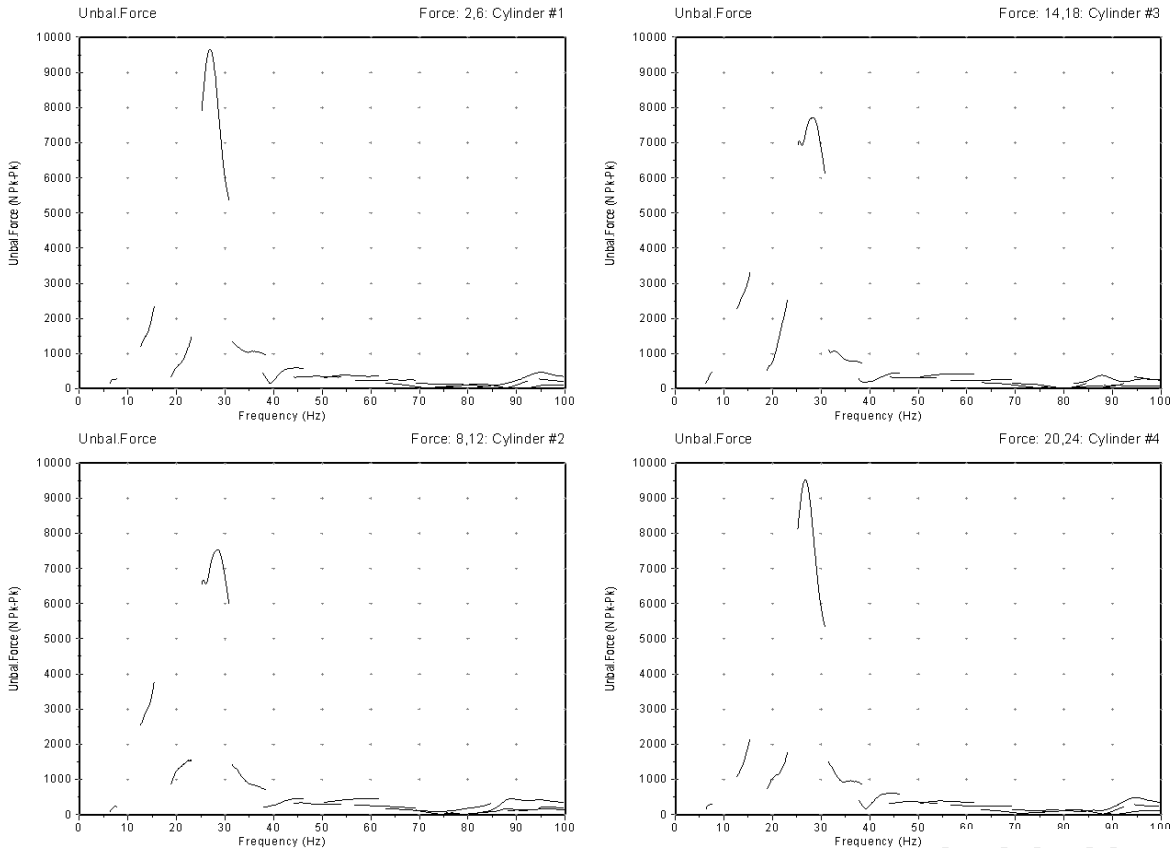

Figure 14: Discharge Cylinder Forces

The cylinder forces are high when each force is considered individually. Since the cylinders are connected to a common bottle and support structure, the vector sum of all the forces needs to be considered. This compressor is a 4 throw unit with 90 degree phasing between the throws. This crank phasing results in the cylinder forces being perfectly in-phase at the 4th order of compressor speed. The vector sum of the cylinder forces is shown in Figure 15, a force magnitude of more than 30 kN peak-peak (6750 lb_f p-p). This combined cylinder force is clearly the cause of the compressor cylinder vibration.

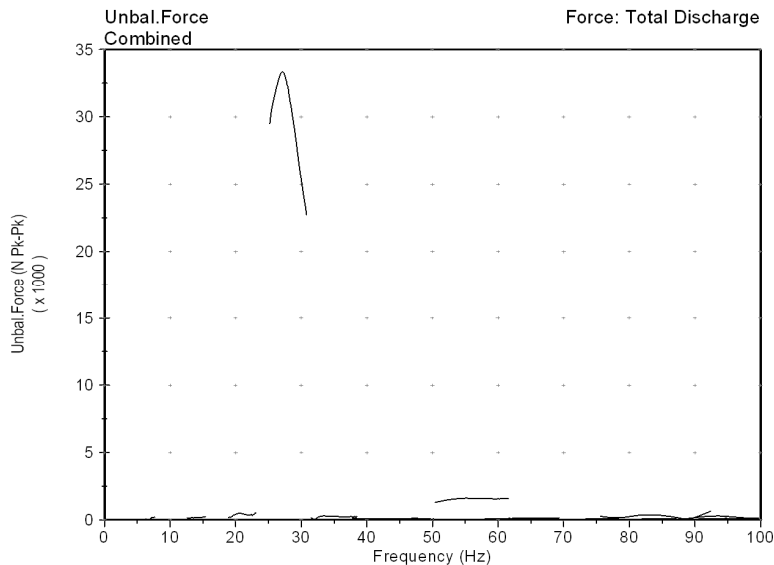

Figure 15: Combined Discharge Cylinder Force

The suction system cylinder force was also evaluated to determine its effect on the cylinder vibration. The suction cylinder force was found to be much lower than the discharge cylinder force. The different gas properties in the suction system as well as the different pulsation energy do not result in high suction cylinder forces.

The discharge pulsation model showed that a $\frac{1}{4}$ wave acoustical resonance between the compressor cylinder and pulsation bottle is the source of the high shaking forces. The calculation of the acoustical resonant frequencies is dependent upon an understanding of the acoustic velocity. As noted in section 2.2.1, the acoustic velocity is dependent upon accurate calculation of the gas properties. The pulsation modeling done in this case study showed that the gas properties were accurately simulated as the measured pulsations agreed with the simulations. The original pulsation model did not accurately calculate the gas properties and the pulsations resulting from the $\frac{1}{4}$ wave resonance.

4.3 Problem Resolution

The cause of the compressor cylinder vibration is obviously the cylinder shaking force from pressure pulsations. Modifications were evaluated with the pulsation model to determine a solution to minimize the cylinder force generate by pressure pulsations. The primary cause of the cylinder force is an acoustical resonance between the compressor cylinder and bottle. One method of changing this acoustical resonance is to install a Helmholtz resonator in the pipe spool. The Helmholtz resonator, named after Hermann von Helmholtz, was first described in the 1850s. A Helmholtz resonator is device with an acoustical resonance that can be tuned to a specific frequency. The resonance frequency can be tuned by changing the volume and/or restriction of the resonator. An example of how a Helmholtz resonator works is an uncorked wine bottle. When air is blown across the opening, a sound is heard at one frequency. The frequency of the sound can be altered by varying the amount of liquid in the bottle. Helmholtz resonators have been used by pulsation designers for many decades to control pressure pulsations in compressor systems. The main benefit of a Helmholtz resonator is that it introduces no (or very small) pressure drop. The downside of resonators is that they are effective over a narrow frequency range and they introduce additional resonances (pass bands) into the system. This compressor installation is an ideal application for a Helmholtz resonator since there is only one acoustic resonance to be eliminated and the compressor has a fixed speed.

Figure 16 is a drawing of the proposed resonator design. The resonator includes a 660 mm (26") section of 6" pipe with a 2" choke tube that is 356mm (14") long to achieve the necessary Helmholtz frequency.

Figure 17 shows the combined suction and discharge cylinder force for all cylinders for the original system design as well as with the Helmholtz resonator installed. The resonator is calculated to reduce the compressor cylinder force to 20% - 40% of the current levels. A similar reduction in vibrations is expected. New spool pieces were fabricated to connect the cylinders with the bottle, which now include the Helmholtz resonators. The spools were installed during an unscheduled shut-down due to work in another part of the facility.

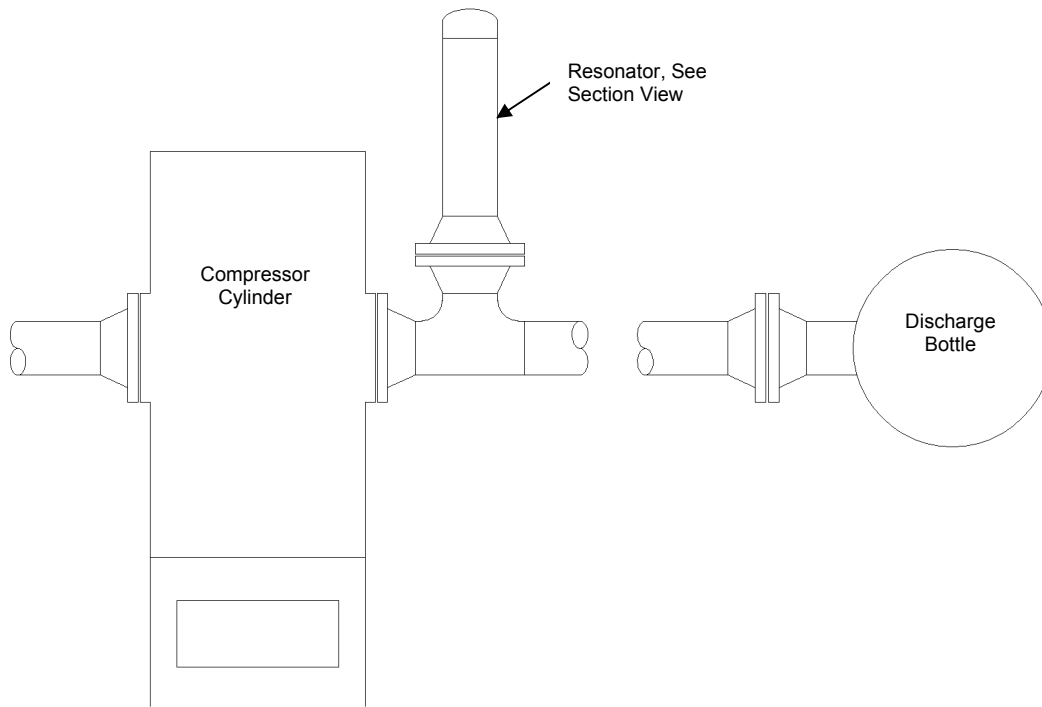

Compressor Cylinder and Discharge Bottle Elevation View

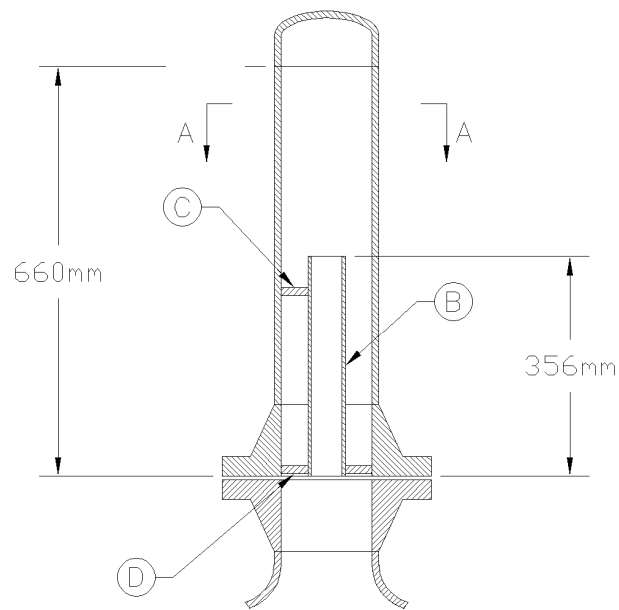

Resonator Section View

Figure 16: Discharge System Elevation and Resonator Section Views

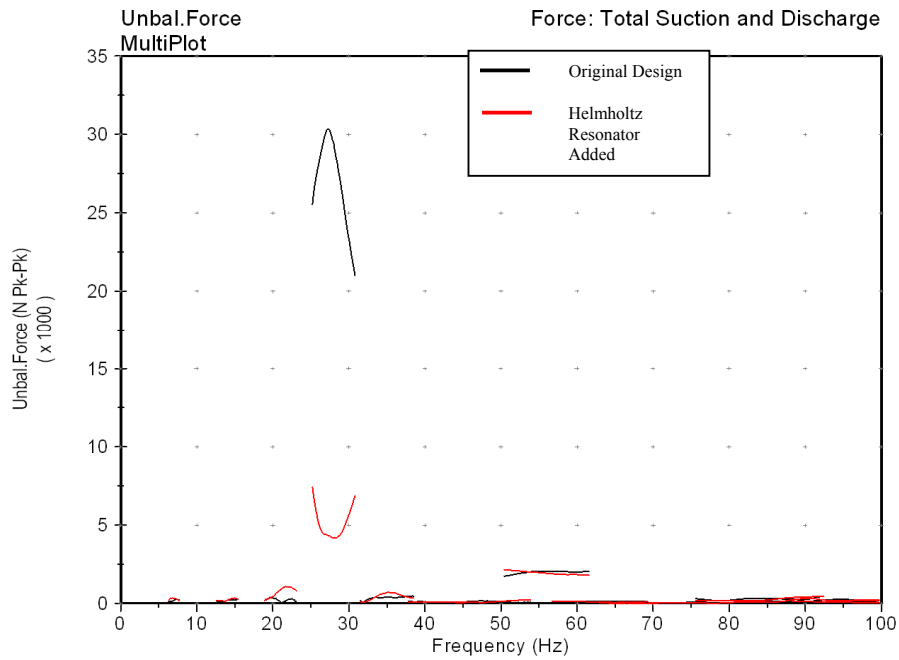

Figure 17: Combined Cylinder Force for Original and Modified Design

Figure 18 shows the overall cylinder vibrations recorded by the vibration transmitters permanently installed on the compressor cylinders before and after the resonators were installed. The resonators were very effective in reducing the cylinder vibrations to acceptable levels from approximately 18 mm/s (0.71 ips) RMS to 7 mm/s (0.28 ips) RMS.

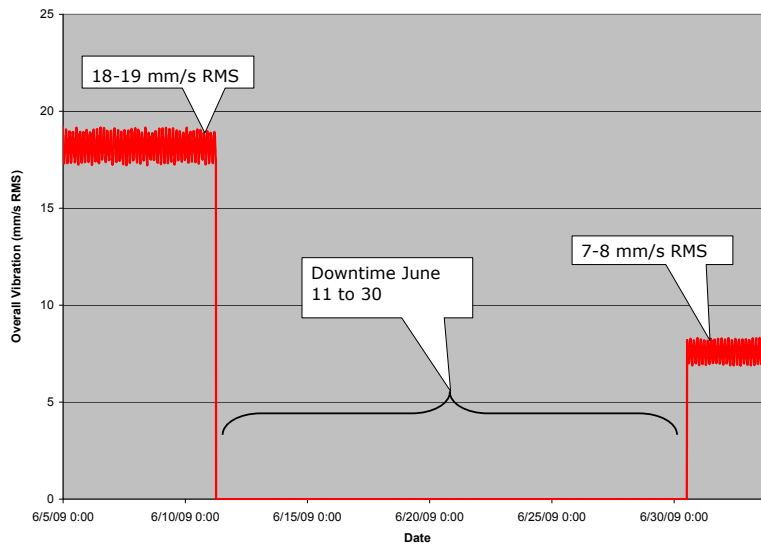

Figure 18: Overall Compressor Cylinder Horizontal Vibration

5 Conclusions

This paper demonstrates that a thorough understanding of specialty gas properties is key to accurately simulating the performance of reciprocating compressors. OEM and commercial performance programs may have difficulty accurately simulating the compressor performance in some applications.

The case studies illustrate the strength of pulsation analysis software that includes consideration of specialty gas properties and a non-linear Time Domain model of the fluid dynamics. Accurately calculating gas properties is crucial to determining the acoustic velocity and acoustical resonances in the piping and vessels. Frequency Domain pulsation software has severe limitations producing less accurate model results, which may compromise the safety of the reciprocating compressor installation.

The design criteria specified in API 618 are the minimum standard for pulsation studies. Other criteria, such as the pulsation generated shaking force between the compressor cylinder and pulsation bottle, must also be considered.

Conducting compressor performance simulations and pulsation studies for specialty gases requires sophisticated, field proven, engineering software.

6 Acknowledgements

Contributions from Brian Howes, Chief Engineer, and Hemanth Satish, Project Analyst, of Beta Machinery Analysis, were significant to the development and implementation of these concepts into Beta's design and field services.

References

- 1 American Petroleum Institute, "Reciprocating Compressors for Petroleum, Chemical, and Gas Industry Services, API Standard 618" 5th Edition, December 2007
- 2 B. Howes, Vertical Forces Cause Vibration in a Reciprocating Compressor, Pipeline and Compressor Research Council – Gas Machinery Conference, 1997
- 3 Gas Processor Suppliers Association, "Engineering Data Book Volume II", Gas Processor Association, 1987