

Spectral Analysis
of
Machinery Vibrations
by
David Schuh – Beta Machinery Analysis Ltd.
Calgary, Alberta

Beta Machinery Analysis was founded by David Schuh in 1967 for the purpose of providing machinery troubleshooting and diagnostics to industrial machinery users on a consulting basis. A real time spectrum analyzer was purchased in 1970. The company today continues to provide machinery analysis services covering rotating and reciprocating machinery.

ABSTRACT

Real time spectrum analyzers have been the most significant recent step forward in signal analysis methods. The benefits are not only increased speed of analysis but compact, easily interpreted results. In recent spectrum analyzers, increased frequency resolution and averaging aid in the interpretation of complex signals (e.g. gearbox vibration). Rapid hard copy capabilities provide practical records for trend analysis.

MACHINERY DIAGNOSTICS

The term "machinery diagnostics" is used here to mean the routine, periodic monitoring of vibration signatures and other parameters to allow a continuing assessment of machinery health. When we decided to offer such a service, it was decided that the instrumentation system should include the following:

- : 2 wheel cart mounting for easy portability
- : a spectrum analyzer
- : a tachometer strobe for phase measurements
- : scope for time base and X-Y display
- : accelerometer power supply, signal conditioning
- : strip chart medium speed recorder for spectra
- : velocity transducer signal conditioner and meter readout

There was no such instrument available in one package, so we assembled the above system using several instruments and mounted this on a custom designed cart. The entire system including the cart is collapsible for storage in cases for air or ground transportation.

With such a system, numerous machines can be analyzed on a normal day. Book keeping requires an additional two or three hours for mounting the strips in a record book. The continuous roll of strip chart paper is sheared into spectra representing the vibration characteristics at each test point. Observations such as coupling hub runout resulting from coupling tooth wear are noted on the strips to act as reminders for the next analysis.

Typically, the velocity spectra from case readings are taken in three directions (horizontal, vertical and axial) near each bearing, accelerometer data to 20,000 Hz is taken from a stud mounted accelerometer on gearboxes and data from all non-contact probes are stored in spectral form. Where once per turn markers are available, the orbits are photographed on the oscilloscope. Where visible, couplings are always examined using the strobe light to check for eccentricity, wear or torque induced distortion. The hands are used routinely to check for movement at shim packs and an ordinary pencil serves as a contact probe for shaft readings on machines running under 6000 RPM. Where abnormal shaft orbits are suspected, a shaft stick attached to a velocity probe is excellent for these machines.

Typical results from machinery diagnostics are shown in Figures 1 and 2 and the forms which we use for book keeping are shown in Figures 3 and 4.

Part of the great increase in speed of analysis results from instant recognition of a healthy machine, (i.e. very low spectrum spikes and absence of harmonics). Minimum time is spent on such a machine (perhaps 10 minutes). To further increase speed and minimize hand writing, we have installed a telephone dial connected to the marker pen on our strip chart recorder. Dialing a "2" will create two short dashes on the side of the strip chart. In this manner we identify the spectrum as to the machine test point, vertical orientation, vertical calibration (.05 in/sec per major division) and horizontal frequency scale (100 Hz). This is done during the five seconds required to output the spectrum on the strip chart recorder and is "dead" operator time anyway.

We have found that diagnostics of this type work best when performed at least four times yearly and backed up by an inhouse vibration monitoring program using small hand-held instruments reading overall vibration velocity.

MACHINERY TROUBLESHOOTING

Machinery troubleshooting places considerably more demands upon the analyst than machinery diagnostics. Ideally, we would want our machinery troubleshooter to be an expert in structural dynamics, rotor dynamics, soil mechanics, lubrication theory and of course, human psychology in order to deal with the conflicting stories told by the plant personnel. Most frequently the evidence of a problem is vibration and we always need the answer to the question, how much vibration at what frequency? The spectrum analyzer provides this answer in the fastest, most easily interpreted fashion complete with hard copy suitable for reports.

To a machinery troubleshooter it sometimes appears that design engineers try to place all the mechanical natural frequencies at or near run speed, vane passing frequency or plunger stroking frequency. In practice a very large percentage of machinery problems involve mechanical resonance. Fortunately about 90% of these mechanical natural frequencies can be determined experimentally by simple shock excitation and the use of a spectrum analyzer. Even in the cases where the system is highly damped and only a few cycles of vibration are obtained from the shock applied, the spectrum analyzer identifies the frequency. The hardcopy output is most convincing and inherently has higher reader credibility than simply a written number.

Figures 5 and 6 show data obtained while troubleshooting a vibration problem in a vertical pump. Mechanical natural frequencies are seen to be near the pump speed of 390 RPM but just far enough away that the vibration levels are not totally unacceptable.

Figure 7 illustrates a vibration problem in the steering column of a truck caused by mechanical natural frequencies coincident with common motor speeds.

Figures 8-10 are from reciprocating compressor piping systems. Figure 8 shows data which was used to diagnose an acoustical resonance problem, while Figure 9 shows a mechanical resonance problem. Figure 10 shows very high pulsations at twice crankshaft speed in the second stage suction.

CONCLUSION

A real time spectrum analyzer is an excellent tool for evaluating and recording case vibration, shaft vibration, gearset accelerometer data, experimentally determined mechanical natural frequencies, and acoustical energy such as liquid pulsation and noise.

FIGURE 1 – Spectrum Analysis – Healthy Machine

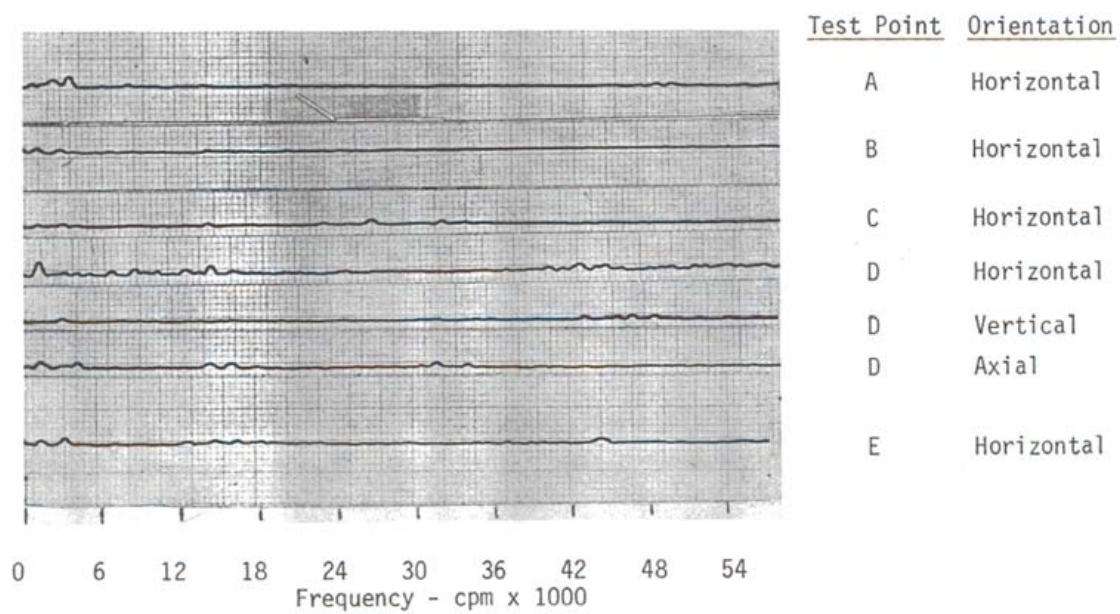
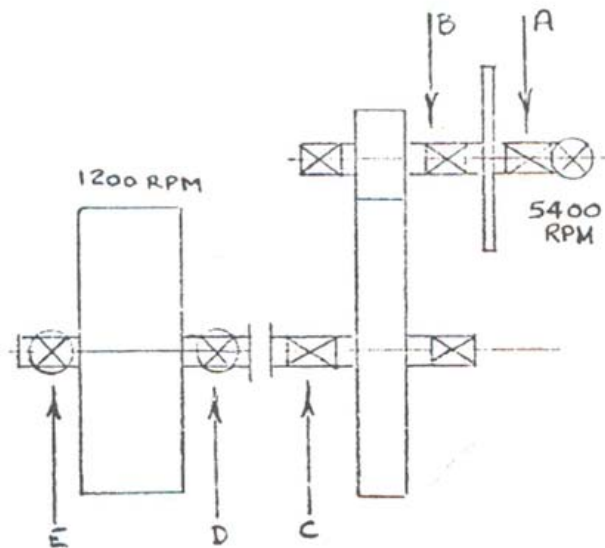
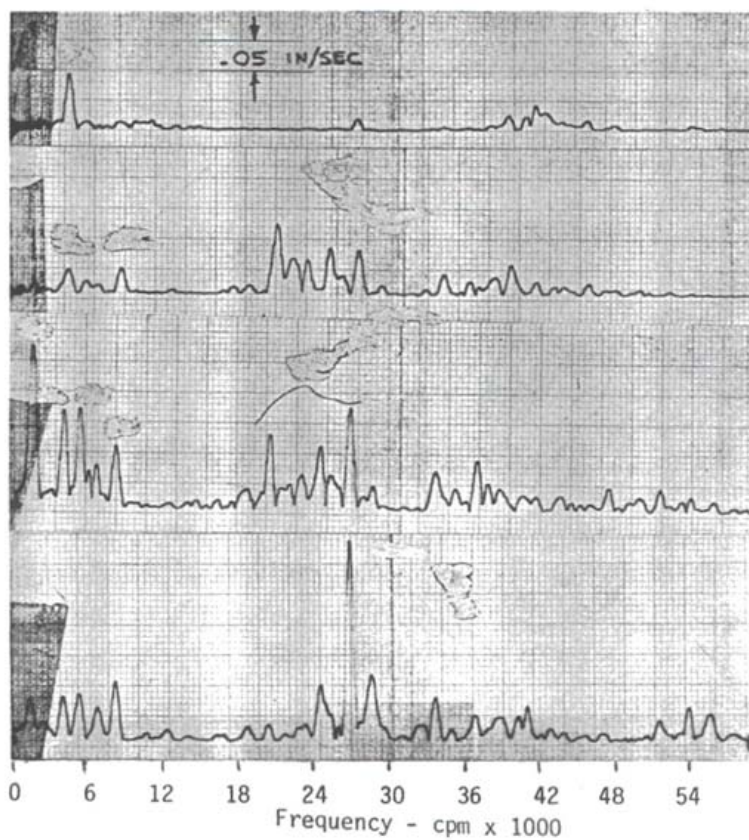
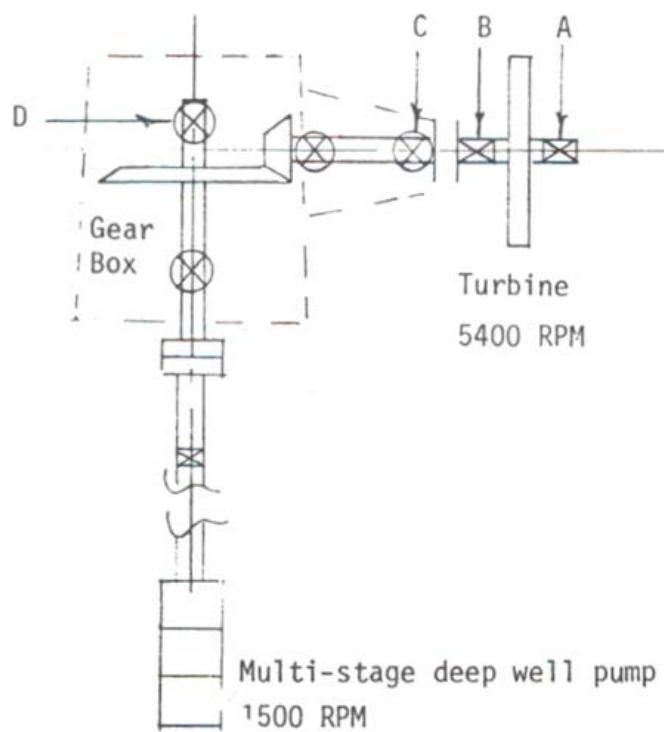

FIGURE 2 – Unhealthy Machine



Test Point Orientation

A Horizontal

B Horizontal

C Horizontal

D Horizontal

FIGURE 5 - Report Format - Pump

Introduction:

The purpose of the analysis reported here was to determine the magnitude and cause of the vibration found near the recently installed pump.

Test Point Description:

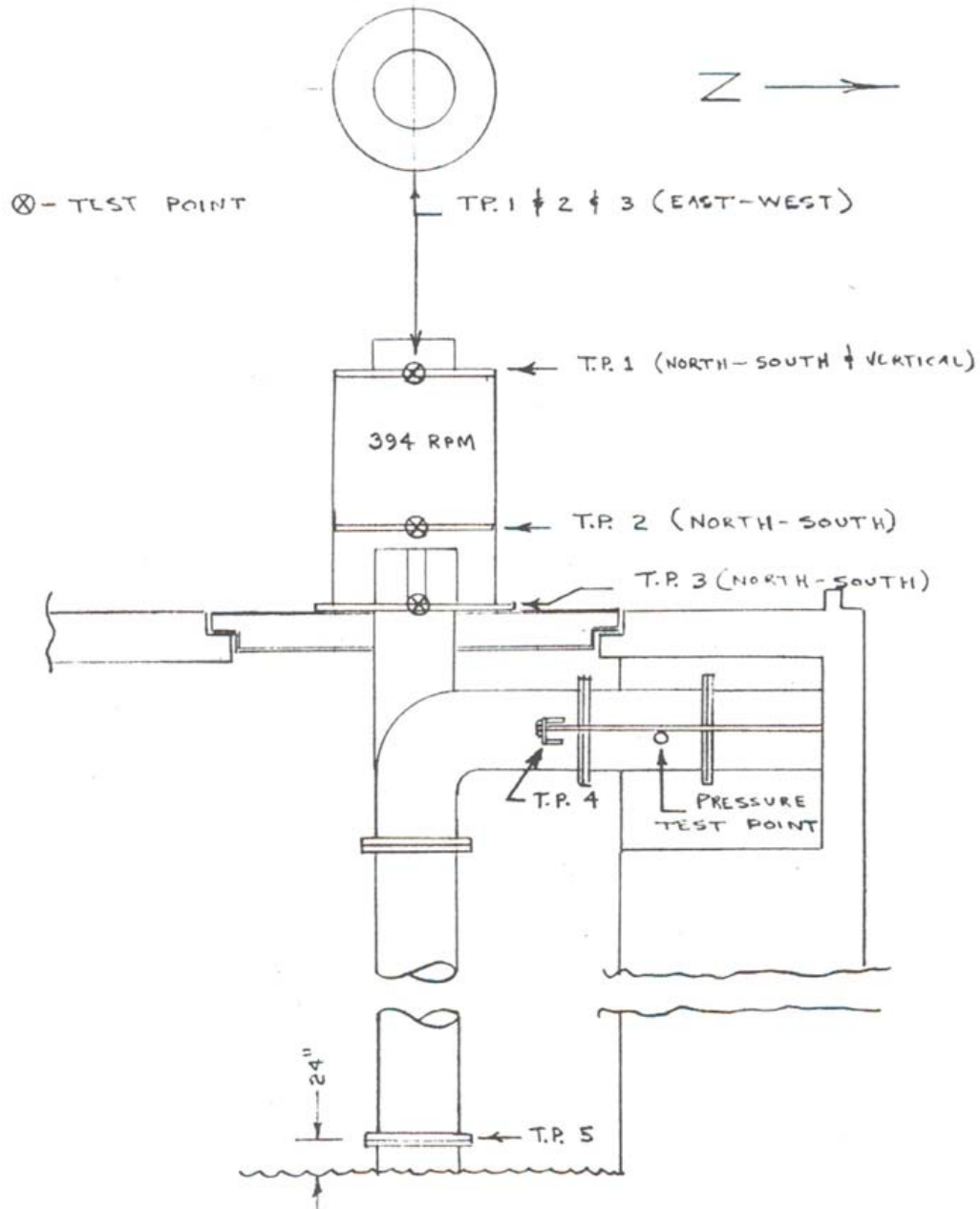

Operation Conditions:

Motor Speed 394 RPM
 Flow 75000 Imperial gallons per minute
 Suction Head - 2 ft below lower flange set
 Discharge Head - estimated at 50 feet

FIGURE 6 - Report Format – Pump

Vibration Data:

Notes: The vibration is presented in the spectrum form. Vibration amplitude (mils peak-to-peak) is the vertical ordinate. The scale is noted on the first spectrum of each page.

The vibration frequency is the horizontal ordinate and the scale is shown on the page bottom.

Mechanical natural frequencies, where obtained, are noted by M.N.F. and refer to the vibration test point and orientation immediately preceding it

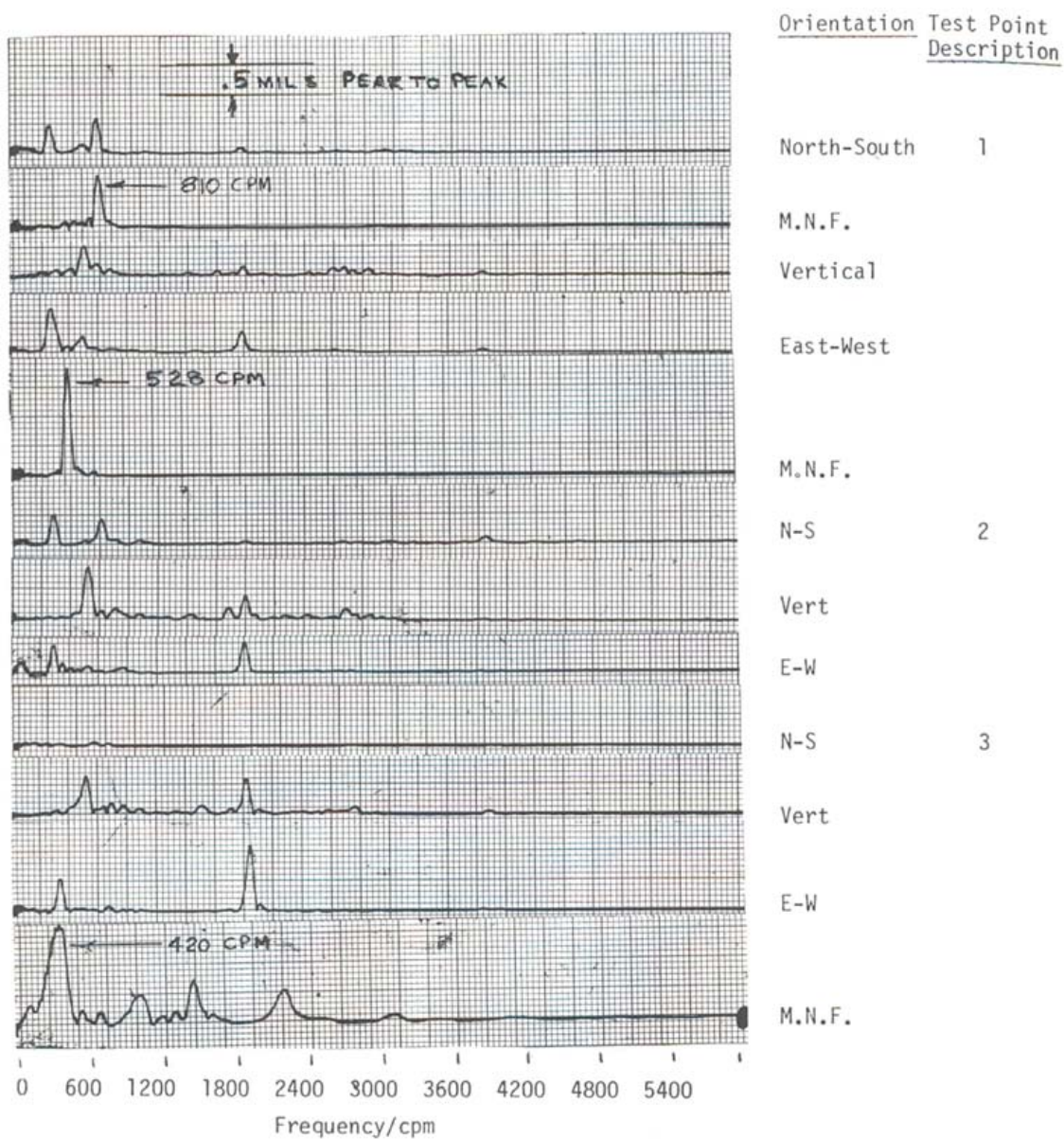

FIGURE 7 – Truck Cab

Vibration Data

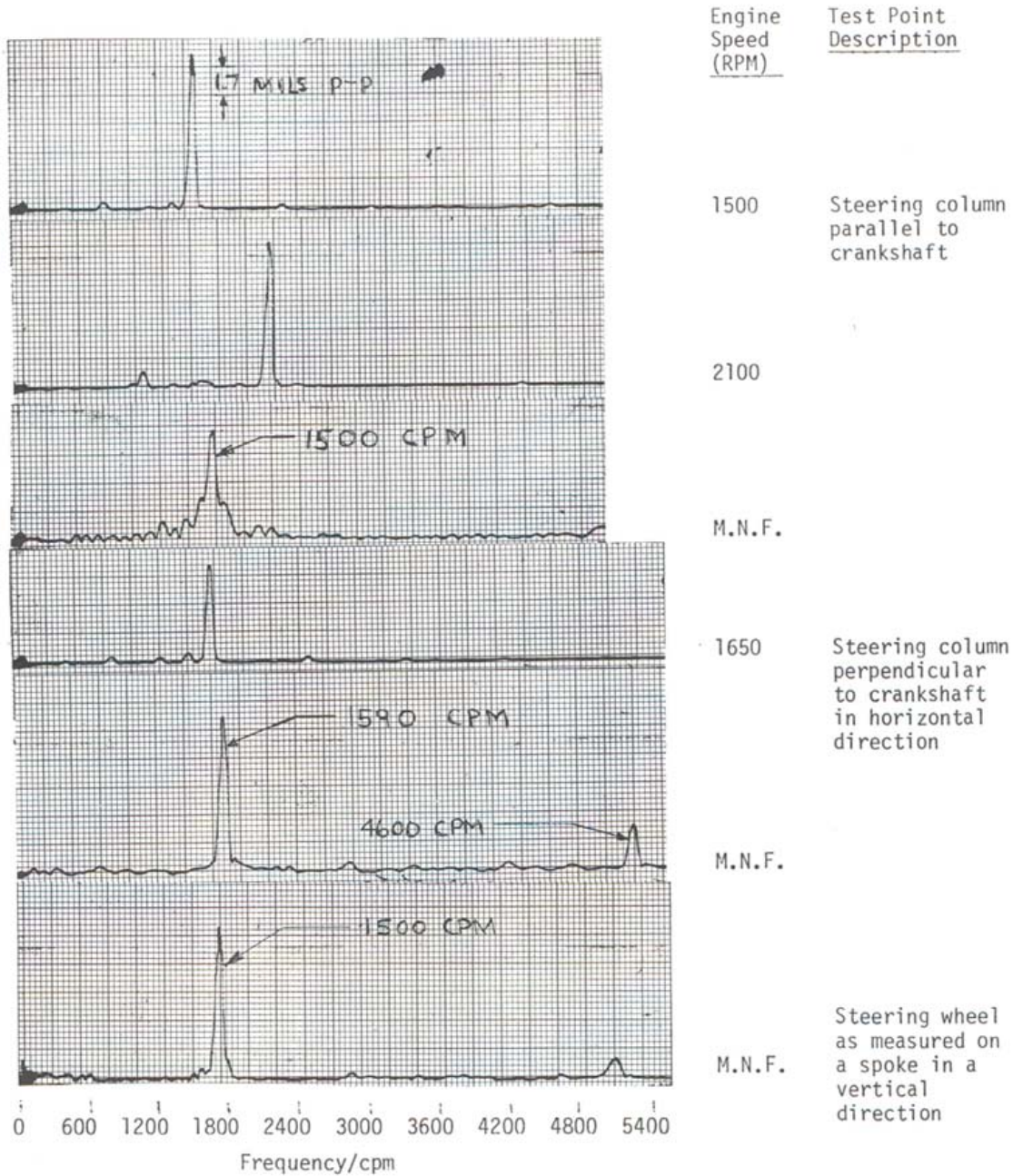
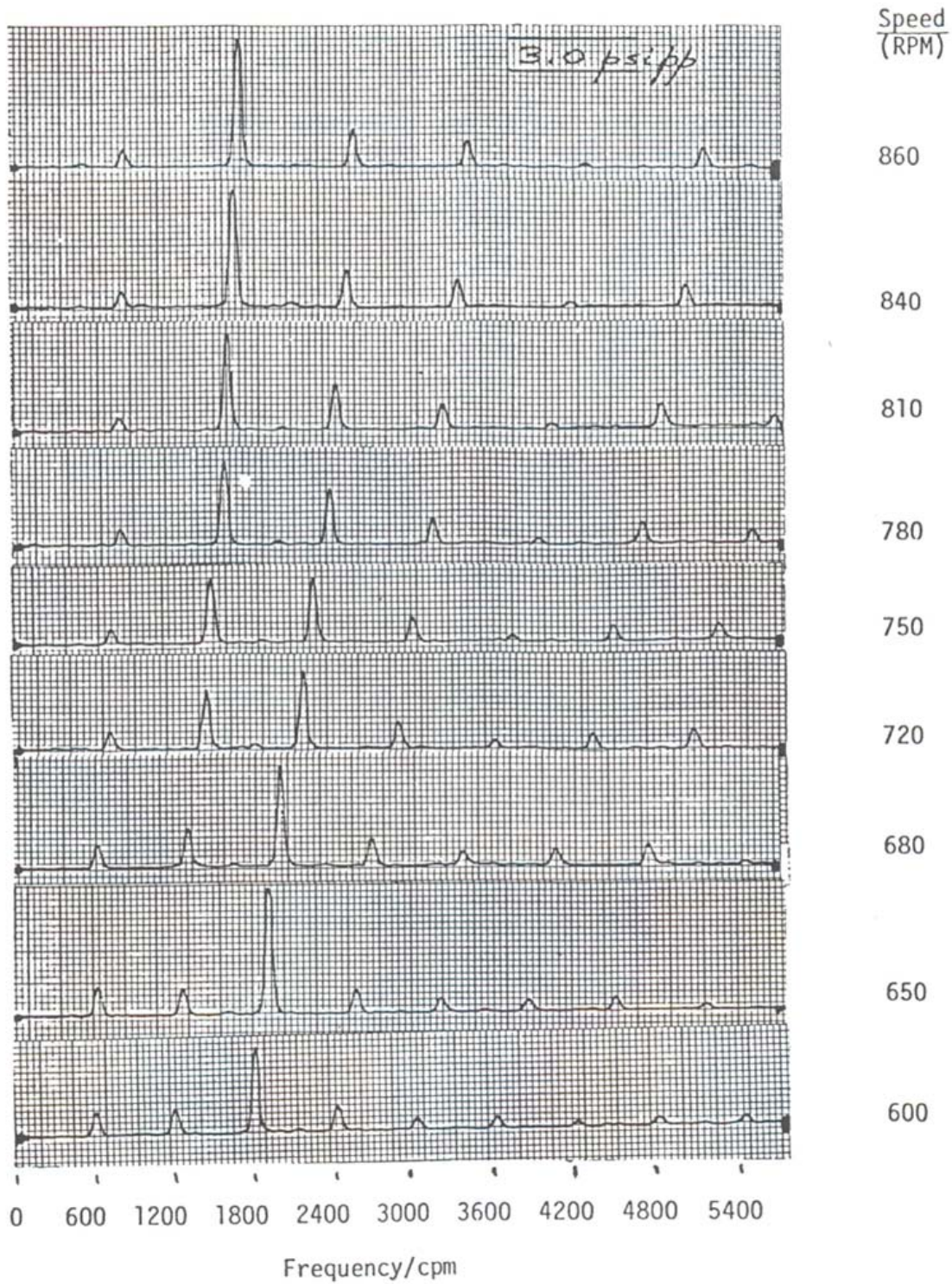

FIGURE 8 – Recip Compressor PipingPulsation DataTest Point: Gas Booster – 1st Stage Suction Bottle Continued

Discussion: This system has a strong acoustical resonance at 1950 cpm.

FIGURE 9 – Recip Compressor Piping

Vibration Data

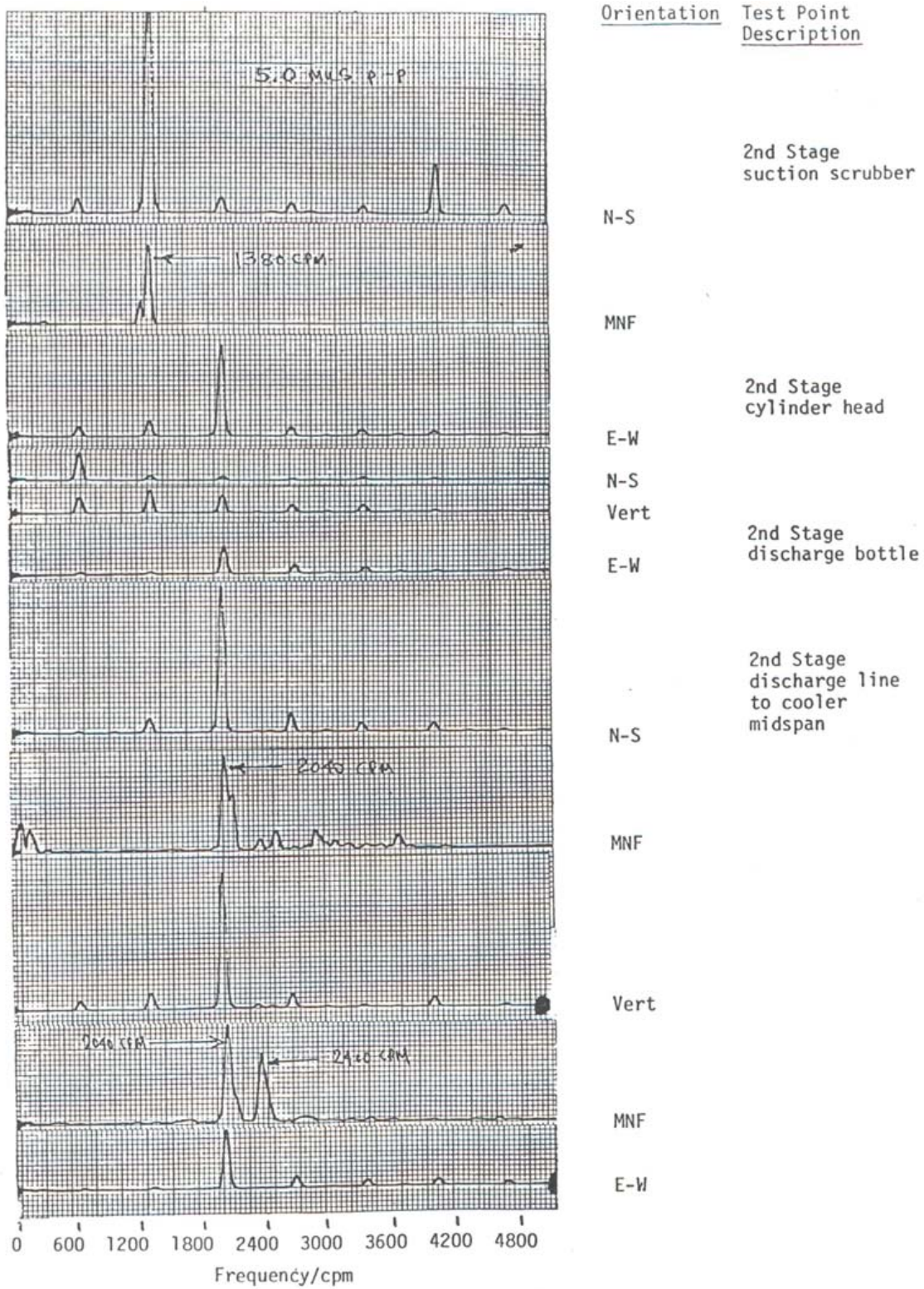

FIGURE 10 – Recip Compressor Pulsation

Pulsation Data

