

## VIBRATIONS IN RECIPROCATING COMPRESSORS

Brian C. Howes  
Beta Machinery Analysis Ltd.  
Calgary, Alberta, Canada

### ABSTRACT

Experience with troubleshooting vibration problems in and around reciprocating compressors leads to several conclusions. Pulsation-induced shaking forces can cause extremely high vibrations on bottles and piping. However, pulsations in the piping or vessels that are shaking, may not be the cause of the high vibrations.

When compressors are installed without benefit of pulsation-control design, problems with high vibrations frequently arise. When troubleshooting those systems, it is advisable to assess the shaking forces in all of the systems, even though one system may appear to be the problem.

Examples are given, along with suggestions for analysis procedures.

### BIOGRAPHICAL SKETCH

(see attached)

### INTRODUCTION:

Vibration problems in reciprocating compressors caused by pressure pulsations are common when proper design procedures are not used. Techniques are available to model the compressor and piping system over the full range of expected conditions, and to reduce pulsations to an acceptable level using efficient methods (both from capital cost and operating cost viewpoints).

Despite the availability of engineering methods to model such systems before they are constructed, many compressor systems are installed without the benefit of dynamic design. In these cases, the odds are high that some sort of problem will develop. Some problems will be obvious in the form of high vibrations. Other problems are more difficult to recognize, such as metering error, compressor performance degradation, decreased valve life, and increased system pressure drop due to dynamic flow oscillations.

This discussion will focus on vibration problems in systems that have not been modelled in the design stage. In such cases, the usual procedure, after identifying that a problem exists, is to have an experienced analyst go to the site and take measurements of pulsations and vibrations. Based on the analysis of the measurements, recommendations are often given at site for correction of all or part of the problems. In the case of problems that appear to be caused by pulsations (as opposed to moments or forces from unbalanced reciprocating weights, torque fluctuations, or cylinder stretch as discussed in Reference 1), some changes can be attempted in the field to reduce the magnitude of the force level (for instance, orifice plates). Often however, changes to pressure vessels are required. In those cases, it is usually more cost-effective to check the performance of modifications before incurring the cost of shutting down the unit and modifying or replacing a pressure vessel.

The temptation to reduce costs by modelling only the pulsations in that part of the system that exhibits the highest vibrations is great. In some cases, however, such a shortcut is regretted. What makes the decision to limit the scope of the model difficult, at times, is the lack of pulsation test points in existing systems. Due to the standing wave nature of pulsations, the quality and quantity of test points are very important. If there are too few test points, or they are poorly located, it is possible to miss the presence of problem-causing pulsations.

Following are two case histories that demonstrate these ideas.

### CASE HISTORY 1:

This history describes a case in which the vibrations of an area of one system were strongly affected by the pulsation-induced forces in the bottles of the other systems. This interaction was surprising because the other systems were not showing the same high vibration symptoms. Reduction of the forces in all of the bottles was required to properly control vibrations on the bottle that was originally of concern.

Refer to Figure 1.1 for an isometric representation of the piping system. This drawing shows the piping near the compressor. All of the piping was included in the pulsation, or “acoustical”, models of the systems. The term “acoustical” is used interchangeably with pulsation. The definition of an acoustical “system” is the piping through which pulsations travel without blockage by solid closures such as valves and blind flanges. In this case, there are three distinct systems: the first stage suction, the interstage piping, and the second stage discharge. The pulsation bottles, or dampeners, are identified as suction or discharge, and by stage number.

The most obvious problem in the as-found system was the extremely high vibration of the free-standing elbow at the outlet of the first stage discharge (1D) bottle in the axial direction. Initial measurements were difficult since the vibration was so bad that the magnetically mounted accelerometers fell off the pipe as the speed of the unit was varied through the resonance. It was not considered prudent to continue testing the system at that time due to the extreme hazard of operating the unit at the resonant condition. Refer to Figure 1.2 for pulsation and vibration data collected in the as-found condition. Note that the axial vibration plot is truncated by the unexpectedly extreme vibration.

The unit was shut down and orifice plates were installed between the cylinders and the first stage discharge bottle. Upon restarting the unit, vibrations were much reduced but still excessive. Refer to Figure 1.3. Also, the pressure drop caused by the orifice plates resulted in added power loss and lost compressor capacity. Continued testing was possible, however, with the reduction in vibrations that had been obtained.

Pulsations and vibrations were measured at the rest of the test points in the system. Analysis of the data (based on experience) suggested that additional orifice plates would further reduce the vibration in the 1D system. The compressor was again shut down and orifice plates were cut and installed, this time in the second stage suction and discharge systems.

There was a crew of about 10 men on site to install the orifice plates. Checks after restarting showed that the vibrations had been reduced not only on the 2S and 2D systems, but on the 1D system as well. Vibrations were reduced to the point that they could be considered acceptable for short term operation. Refer to Figure 1.4.

Unfortunately, the pressure drops due to the plates were considered unacceptably high for long term operation. Other modifications were available to reduced pulsations with less pressure drop. However, as the other possibilities for correcting the problems in the permanent manner required cutting open the bottles, it was decided to model the system pulsations. The bottle unbalanced forces from the modelling are summarized in Figure 1.5, 1.6, 1.7 and 1.8. The results of the modelling confirm that not only could unbalanced forces be reduced more by means other than orifice plates at the cylinder nozzles, but the pressure drops, and hence the long term operating costs could also be reduced compared to the orifice solution. Note that the model study showed that changes to the first stage suction system also were needed, a conclusion that was not obvious in the field. Experience shows that allowing excessive unbalanced forces to remain in a system leads to problems such as premature wear and ongoing maintenance due to loosening fasteners, etc. even when the vibrations are nominally acceptable.

## CASE HISTORY 2:

The compressor in this example also had a problem with vibrations after startup. A computer model study of the pulsations in the suction and discharge systems was commissioned by the owner. No field visit was performed before the computer model study.

The main complaints were “low” frequency vibrations (ie: one or two times crankshaft speed) on the riser to the suction bottle, and “high” and “low” frequency vibrations on the discharge bottle and piping. Refer to Figure 2.1 for an isometric sketch of the system.

The model study defined several problems of high unbalanced forces in the suction and discharge piping and bottles. Several recommendations were given. Some of the easier recommendations for acoustical and mechanical changes were implemented first. Improvements were observed in the low frequency vibrations in the suction and discharge. However, the high frequency vibrations and suction piping got worse. No detailed measurements were available to confirm the observations.

Upon reflection, it was concluded that, since the high frequency vibrations were worst on the suction bottle and piping, then the problem was most likely caused by residual forces in the suction bottle left by the orifice plate modification. It was decided to continue with the original recommendations and install a baffle in the suction bottle. The reasoning was that it might not be necessary to incur the expense of modifying the discharge bottle too.

Vibrations observed after the suction bottle had been changed were reportedly unimproved. As a result of this lack of improvement, the owner decided to commission a field trip before implementing the recommended changes on the discharge bottle.

The field investigation determined the problem frequency to be 73 Hz, with the operating mode shape of the bottles to be the suction bottle moving “out-of-phase” relative to the discharge bottle. Refer to Figure 2.2. The motion of the piping at the inlet to the suction bottle further amplified the motion of the suction bottle. Pulsation and vibration spectra (peak hold over the speed range of 450 to 600 RPM) are shown in Figure 2.3 and 2.4. The pulsation plots show both predicted and measured pulsations.

The natural dynamic vibration response of the suction and discharge bottles is shown in Figure 2.5. The upper plot shows the point response of the end of the suction bottle in the axial direction. The lower plot shows the transfer response due to exciting the discharge bottle in the axial direction and measuring the response of the suction bottle in the axial direction. The modal response at 73 Hz can be inferred from the phase data. The natural mode shape is similar to the operating mode shape shown in Figure 2.2. Note that there is a significant response at the suction bottle when the discharge bottle is excited. This interaction between the discharge and the suction is not always present in compressor piping systems. Usually, there are wedge supports under the discharge bottles which help to decouple the bottles.

The conclusion of the analysis of the field data was that the discharge bottle unbalanced forces must be controlled to eliminate the high vibrations on the suction piping. The changes were subsequently made and vibrations decreased as expected.

The plots in Figure 2.6 and 2.7 show the predicted amplitude and phase of the unbalanced forces in the suction and discharge bottles. The frequency at which the unbalanced forces peak in the suction bottle is further from the peak natural response shown in Figure 2.5 than is the peak response frequency of the discharge bottle unbalanced forces. Also, the predicted forces in the discharge bottle are higher at 73 Hz than in the suction bottle. These observations explain why the 73 Hz vibrations were essentially unchanged after modifying the suction bottle, but by lowering the forces across the discharge bottle, the high vibration of the suction piping was reduced.

## DISCUSSION:

Several lessons are available in these case histories. Fixing vibration problems in existing compressor installations requires, in general, a field visit in order to efficiently determine solutions. All systems need to be examined carefully for pulsations that might be contributing to vibrations. If the pulsation test points are limited, it is advisable to model all of the systems, rather than only the one system that is obviously vibrating. Field modifications can help to clarify these situations.

A lesson can be extrapolated from the case in which a strong interaction was present between systems. Reducing pulsations in one area can, in principle, increase vibrations in other areas of the piping, an observation that has been reported on occasion. Force vectors from one section of piping can be phased such that they cancel some of the effect of forces in another section. In such a case, removal of one vector will leave a larger resultant vector, and higher vibrations.

Techniques that can help to diagnose such problems include measurement of transfer dynamic response between bottles in a system, and the phase relationship between pulsations. These data help to show situations where a high degree of interaction is present and where pulsation-induced unbalanced forces are adding or cancelling. A caution would be that unbalanced forces do not necessarily peak at the same frequency as pulsations do. Sometimes, therefore, pulsation measurements can be misleading.

Other techniques that aid in diagnosing problems involve making changes that reduce pulsations in one of the systems at a time, such as the addition of orifice plates. Careful examination of the effects of each change can be informative in determining the sources of problems.

Several solutions are usually available to reduce vibrations caused by pulsation-induced forces. The economics of each solution should be analyzed. The most obvious economic considerations are operating costs, reflecting in the added pressure drops from the modifications, and capital costs, reflected in the complexity of the changes.

#### ACKNOWLEDGEMENT:

The preparation of this paper would not have been possible without the assistance of my associates at Beta Machinery Analysis Ltd. In particular, the assistance of C. Schuh and J. Harvey was invaluable.

“Cylinder Stretch as a Source of Vibration in Reciprocating Compressors”. B.C. Howes, K.N. Eberle, and V. Zacharias, Focus on Mechanical Failures: Mechanisms and Detection, 45<sup>th</sup> meeting of the Machinery Failure Prevention Group, 1991

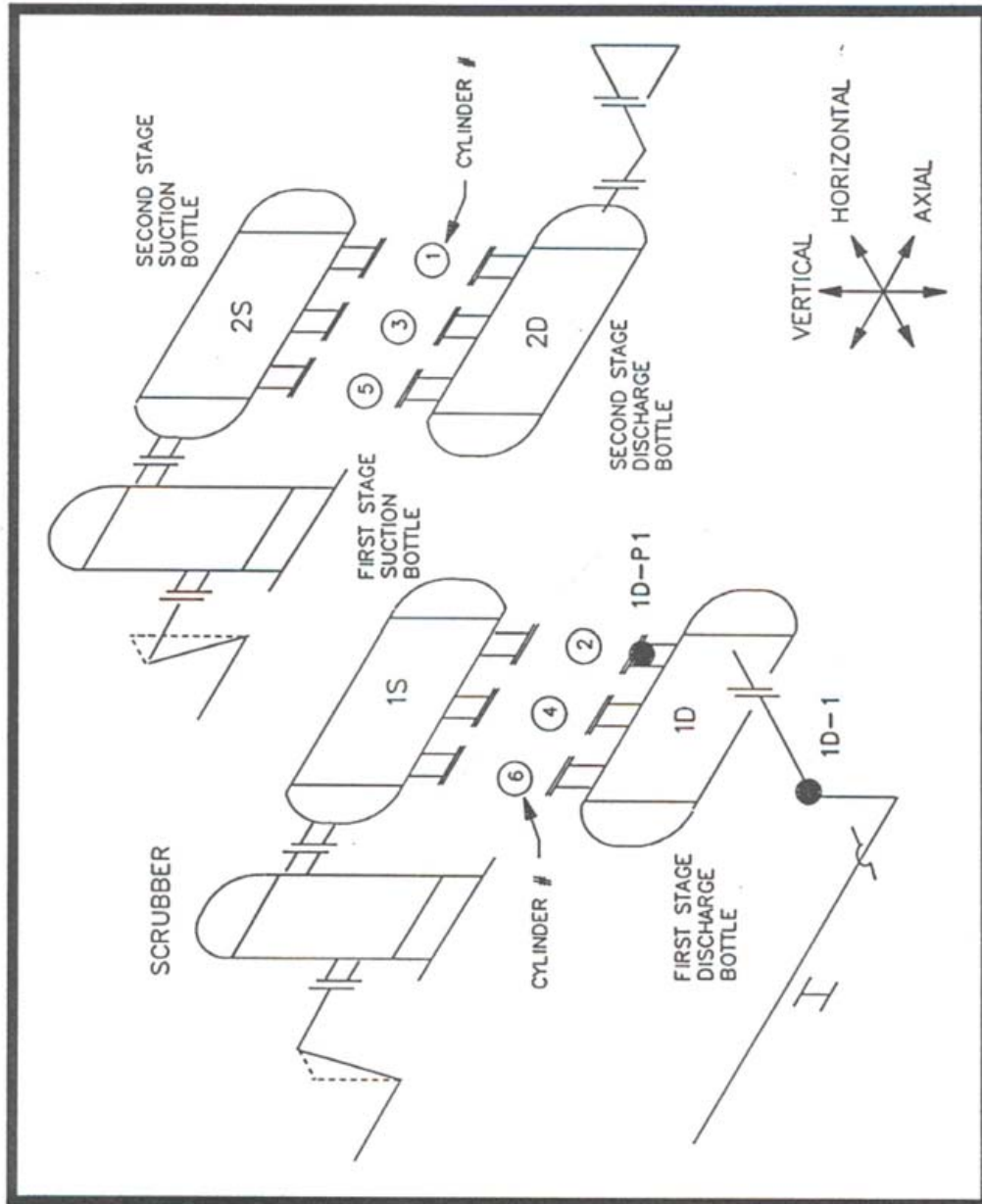

Figure 1.1 – Case History 1: System Layout

Figure 1.2 – Case History 1: As-Found Pulsation and Vibration Data

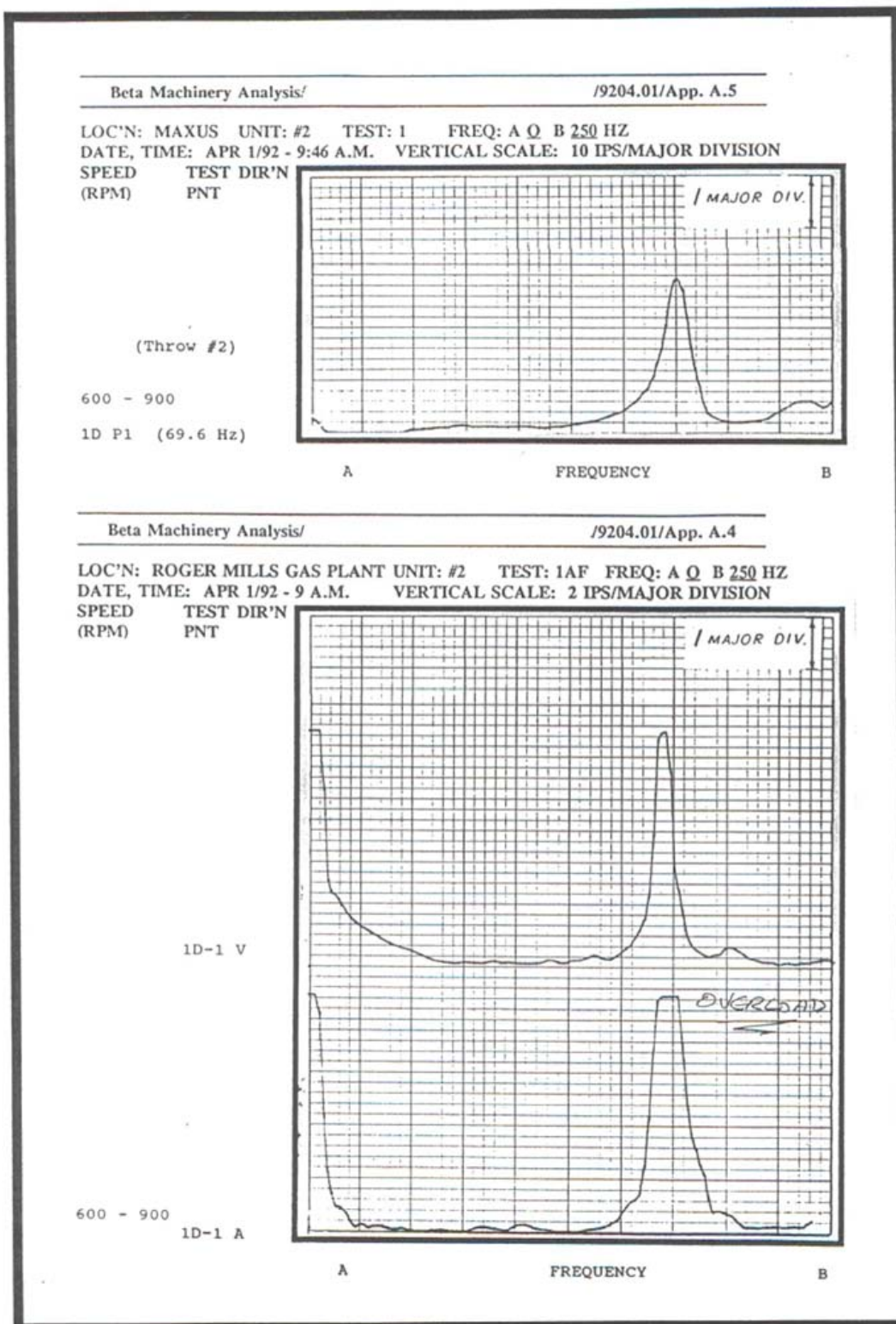

Figure 1.3 – Case History 1: Pulsations and Vibrations after additional 1D orifice plates

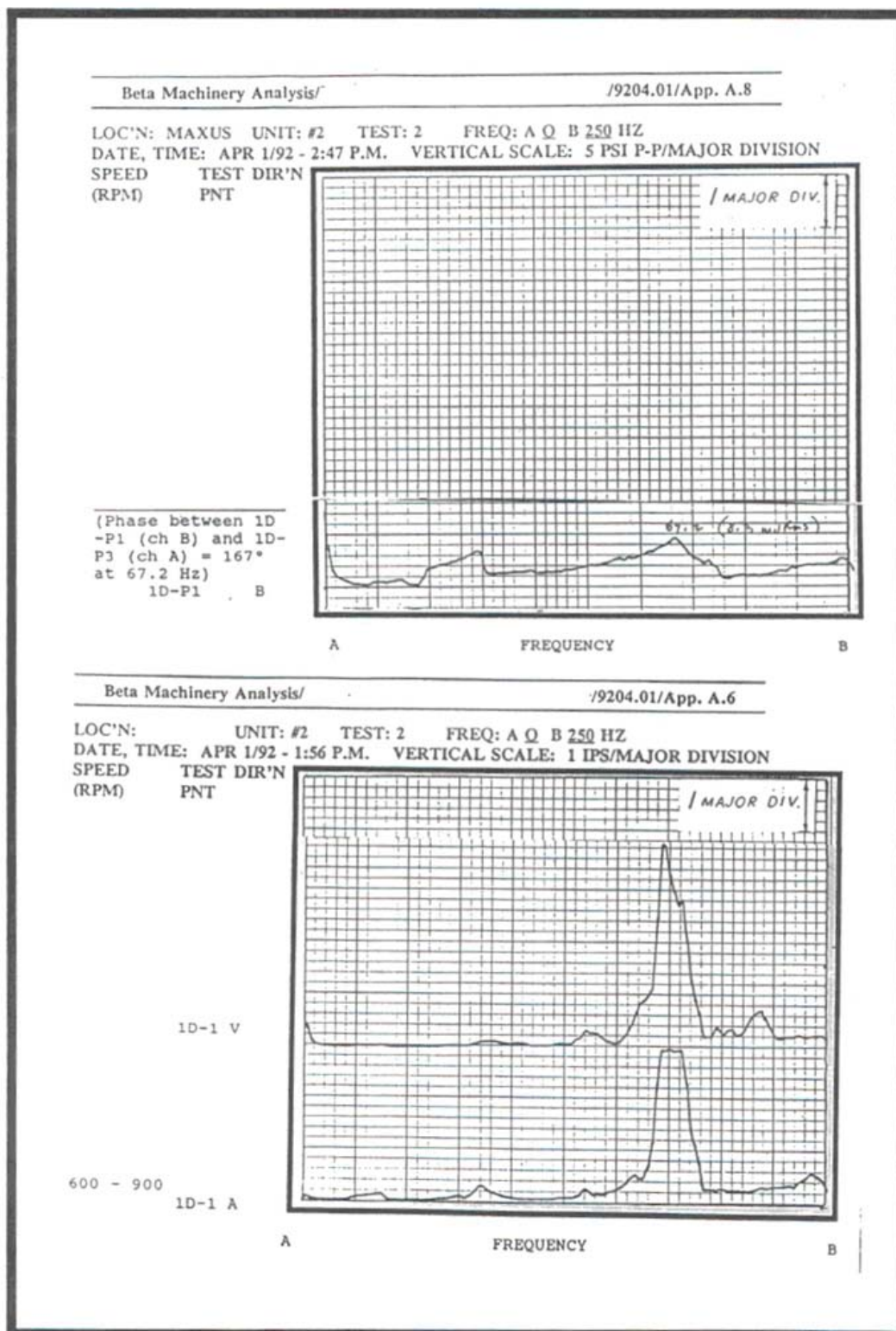

Figure 1.4 – Case History 1: Vibrations after addition of 2S and 2D orifice plates

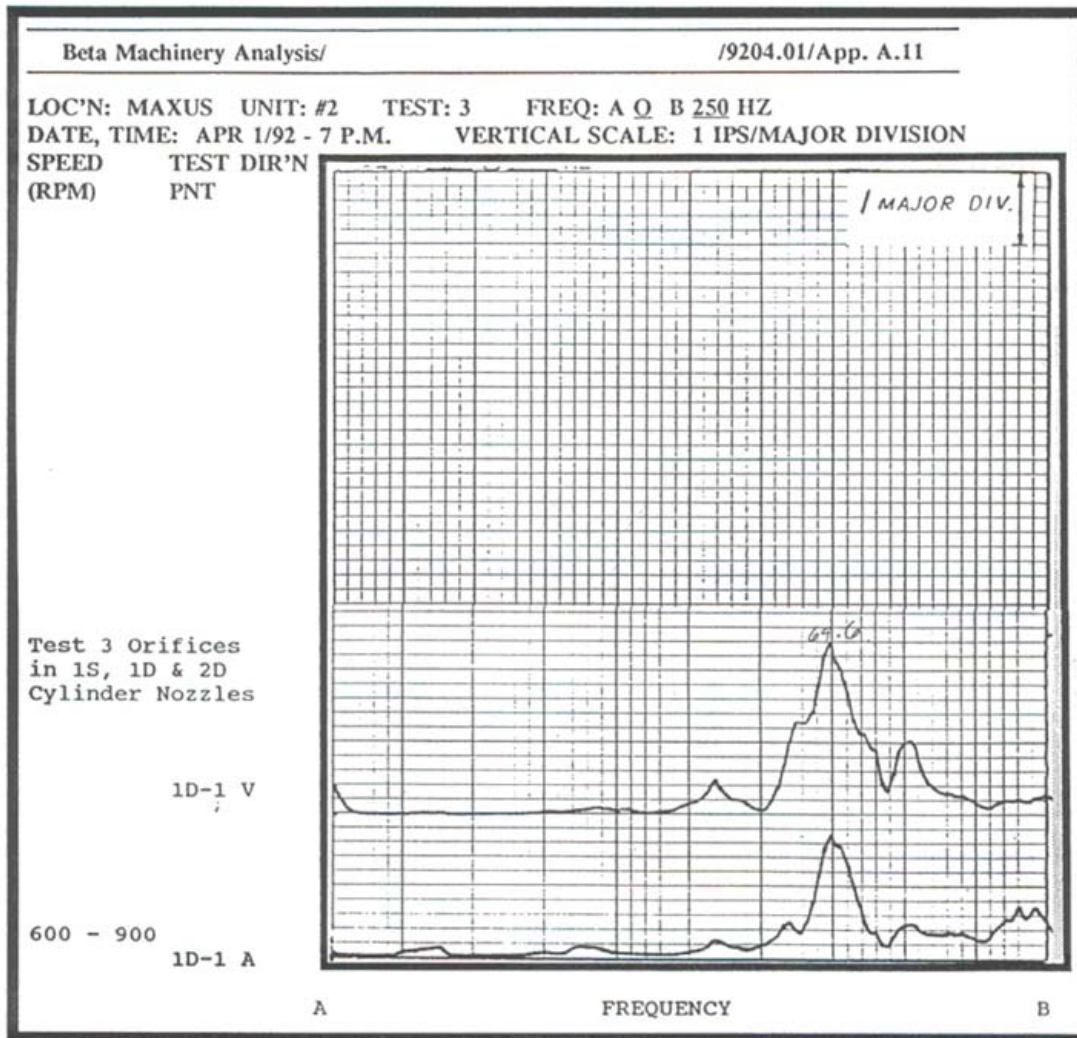

Figure 1.5 – Case History 1: Predicted unbalance forces in the 1S Bottle

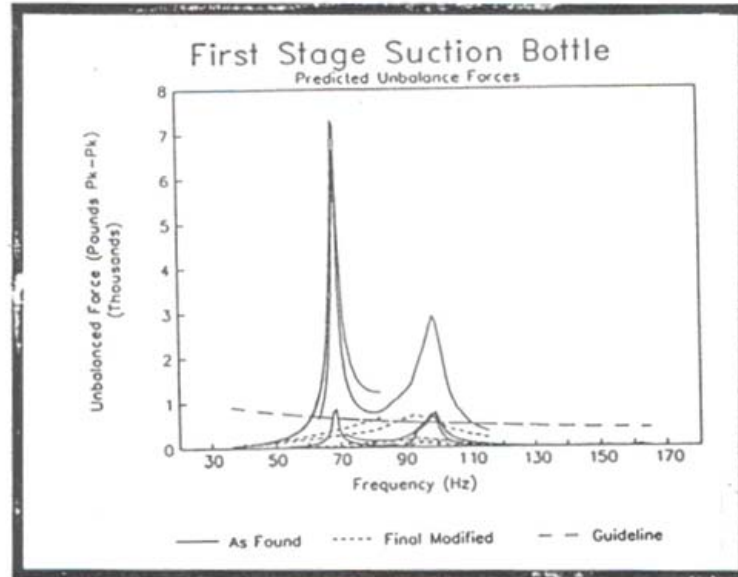

Figure 1.6 – Case History 1: Predicted Unbalance Forces in the 1D Bottle

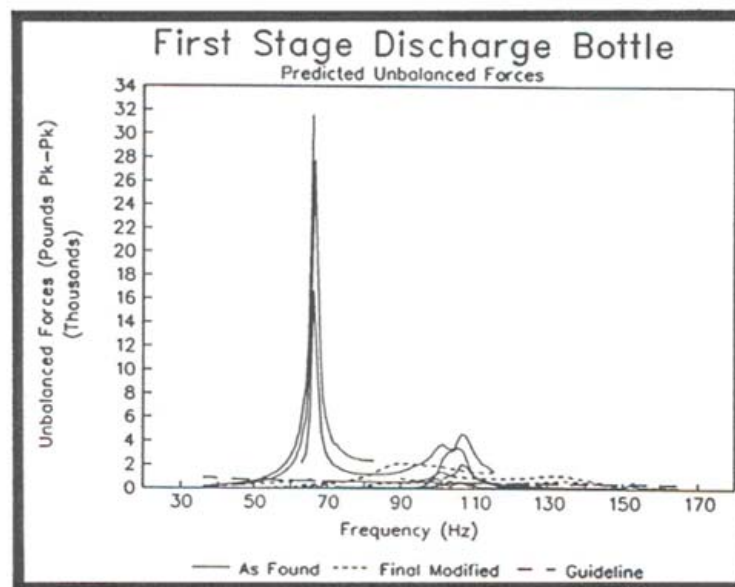

Figure 1.7 – Case History 1: Predicted unbalance forces in the 2S Bottle

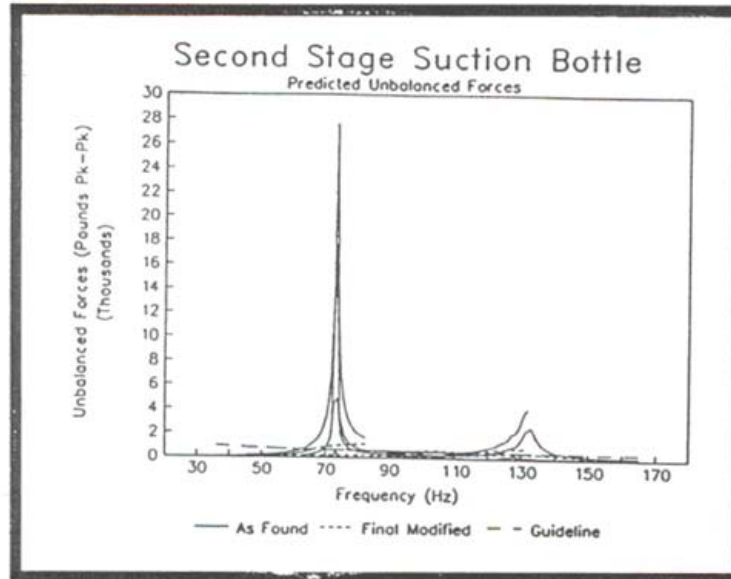
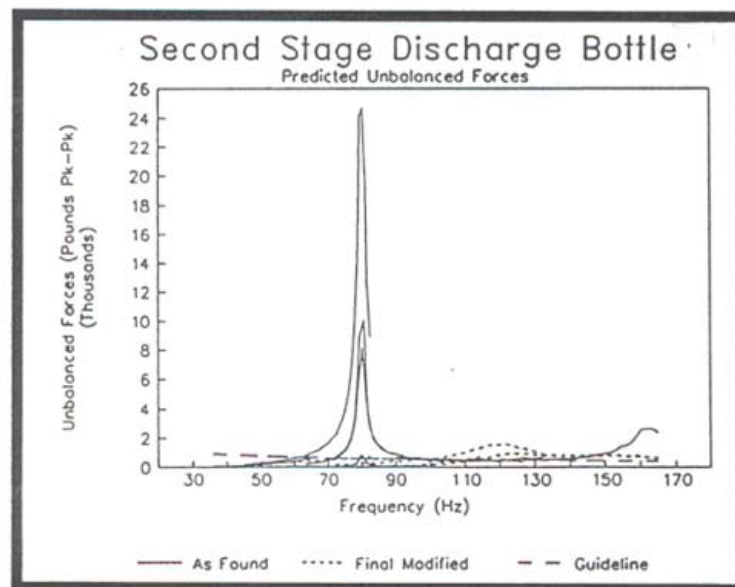

Figure 1.8 – Case History 1: Predicted Unbalance Forces in the 2D Bottle



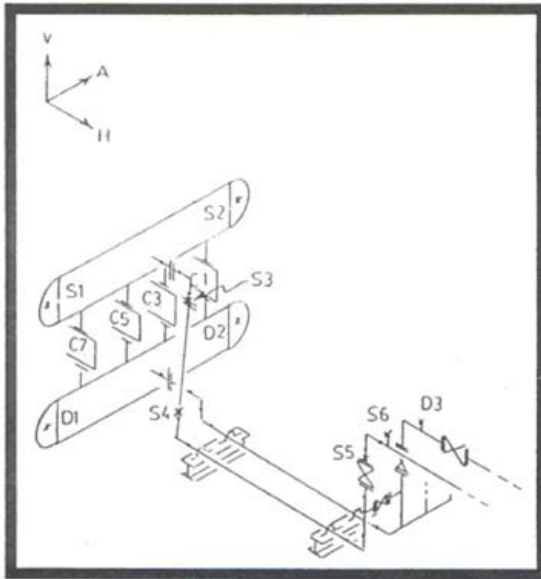

Figure 2.1 – Case History 2:  
System Layout

Figure 2.2 – Case History 2: Running  
Vibration Mode Shape at 73 Hz

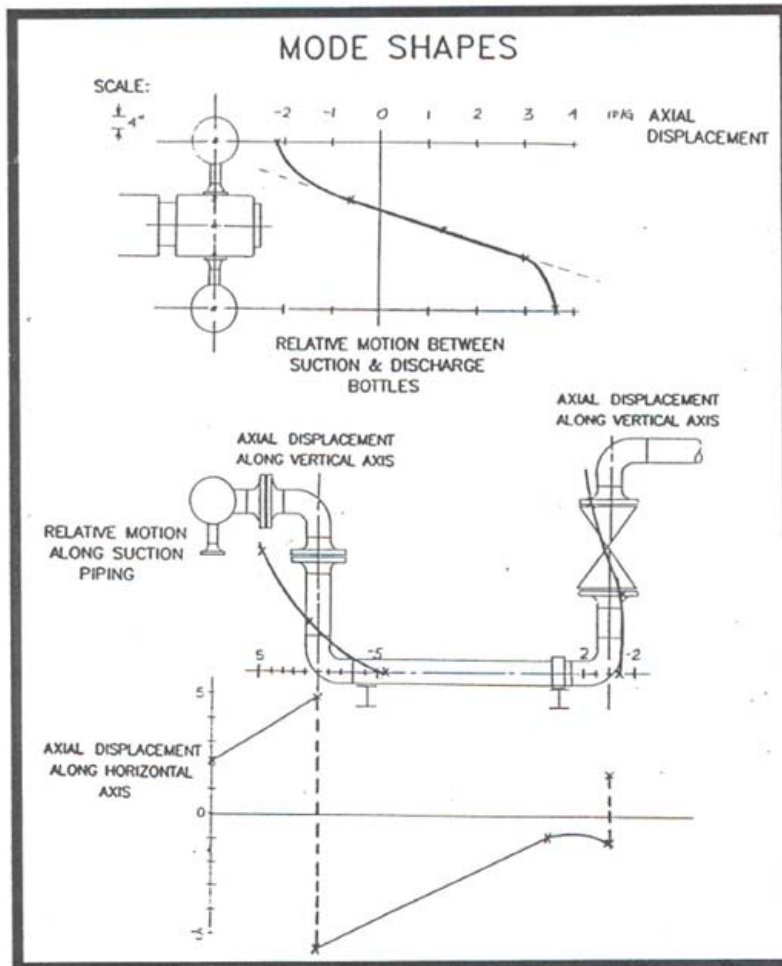

Figure 2.3 – Case History 2: Pulsation Data from Field Measurements and Predictions

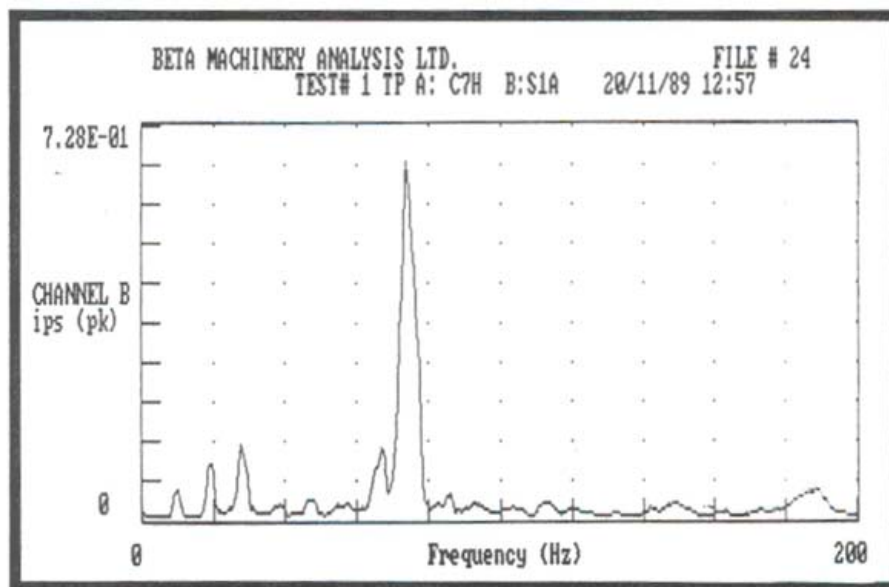
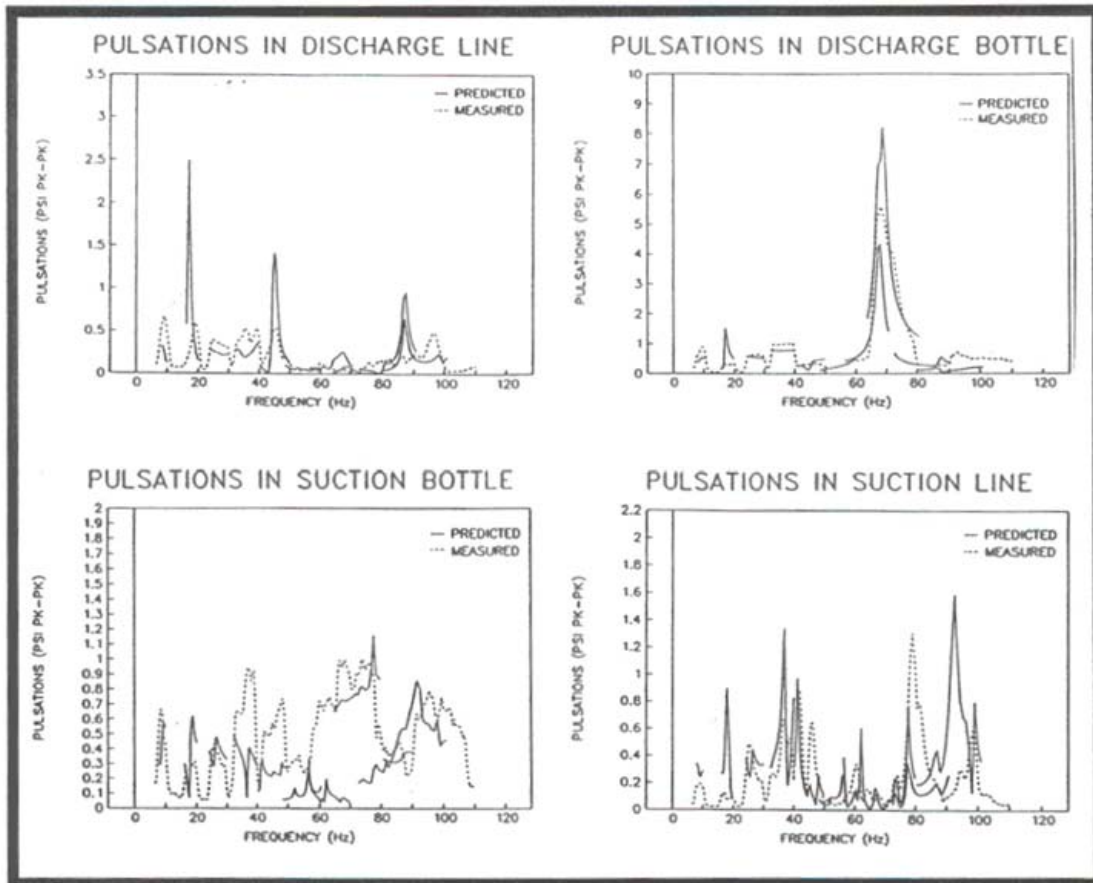

Figure 2.4 – Case History 2: Vibration Data from Field Measurements

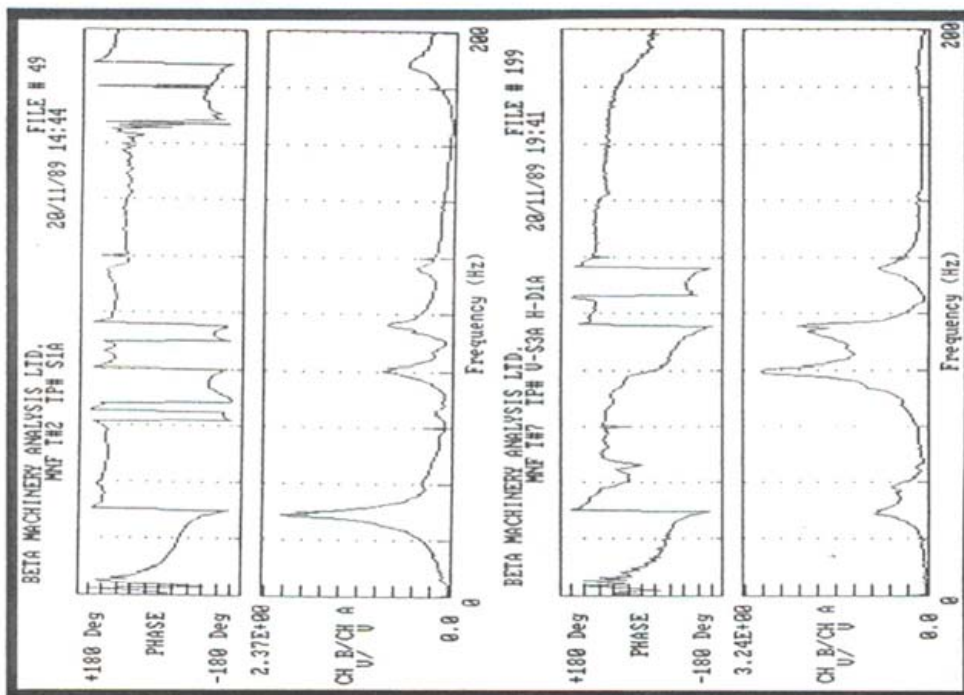

Figure 2.5 – Case History 2: Dynamic Response Data for the Suction and Discharge Bottle in the Axial Direction

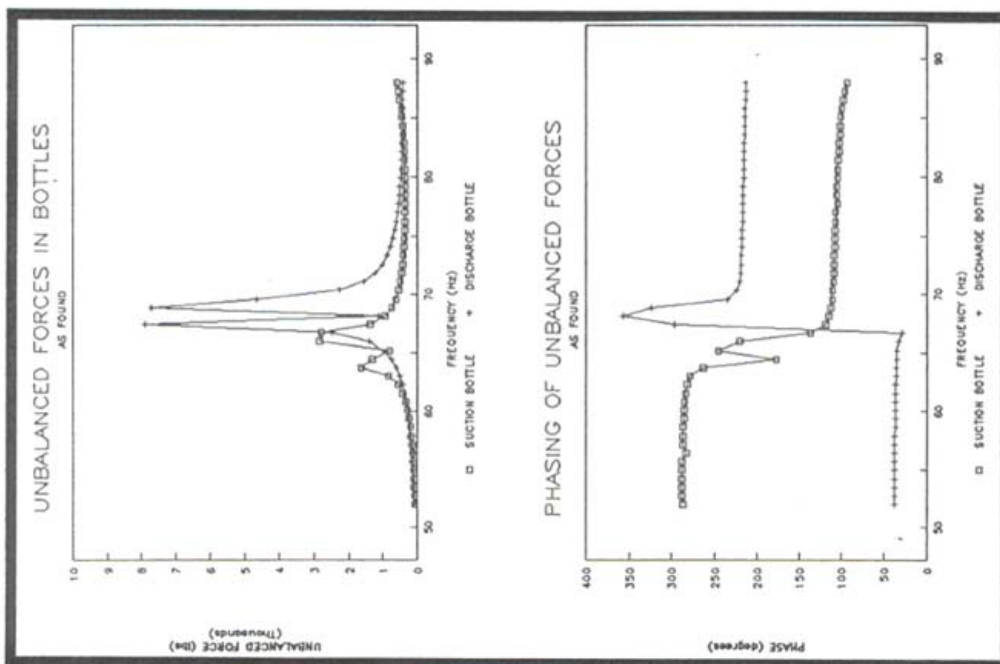

Figure 2.6 – Case History 2: Unbalanced forces and phasing of the unmodified system

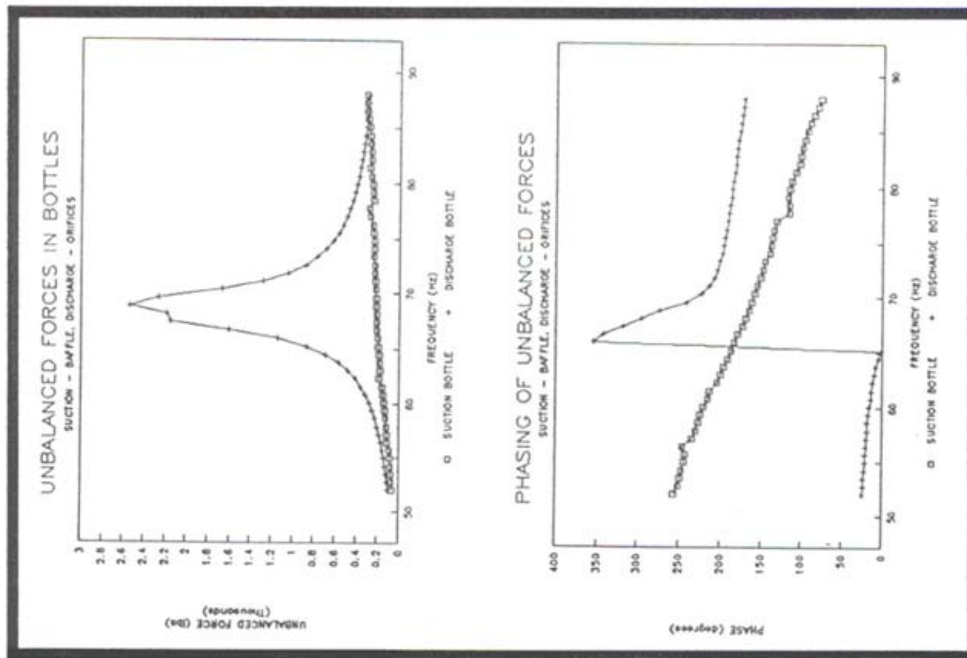

Figure 2.7 – Case History 2: Unbalanced forces and phasing of the bottles – suction system contains baffle and orifices – discharge system contains orifices only.

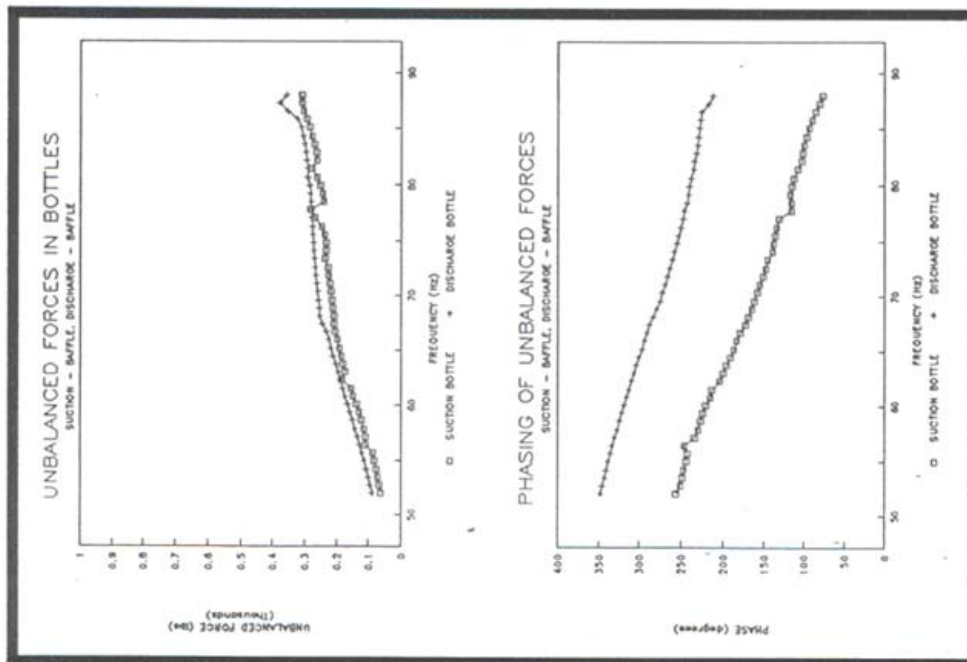

Figure 2.8 – Case History 2: Unbalanced forces and phasing of the unmodified system of orifices – discharge system contains baffles and orifices.