



**MACHINERY ANALYSIS**

# **Optimizing the Pulsation Control Solution**

by:

**Greenfield, Shelley**

**Beta Machinery Analysis**

**Calgary, Alberta**

**Canada**

**[sgreenfield@BetaMachinery.com](mailto:sgreenfield@BetaMachinery.com)**

**6<sup>th</sup> Conference of the EFRC  
October 28<sup>th</sup> / 29<sup>th</sup>, 2008, Düsseldorf**

## **Abstract:**

Reciprocating compressors require pulsation control to avoid large dynamic acoustical forces. A pulsation analysis (per API 618) will recommend a pulsation control solution based on the operating conditions, speed range, and other operating factors. Given these different issues, there are many possible solutions – each with a different result in terms of upfront and operating cost, pulsation reduction, and operating risk.

Owners and packagers are becoming more interested in an optimized pulsation design. This paper presents case studies and design ideas on how to optimize the pulsation control solution. These examples illustrate the significant cost savings and operational benefits available to the industry.

## 1 Introduction

The 5<sup>th</sup> Edition of API 618 (the Standard) was officially released in December 2007. A common theme through the new specification is energy conservation and optimization. The Standard specifies minimum design requirements. It does not require the compressor suppliers to utilize proven design techniques that improve efficiency and performance. To address this issue, the updated 5<sup>th</sup> Edition recommends **innovative approaches “should be aggressively pursued by the manufacturer [packager] and end user [owner/operator]” during the compressor design and operation to reduce the total life costs and increase energy conservation.**

Improving efficiency and reducing the total life cost can be accomplished through different points of view. Three areas that can result in significant savings are:

1. Pulsation control devices introduce pressure drop into the system. Design modifications that result in lower “total pressure drop” through the system can realize a significant financial reward. Reducing pressure drop results in increased capacity, or reduced fuel costs. Increased capacity generates millions of dollars (per year) in incremental throughput. Fuel savings can generate hundreds of thousand dollars per year in savings.
2. Overly conservative pulsation control solutions may result in higher manufacturing cost for the packager/owner. For example, Beta recently saved a packager over \$100,000 in manufacturing costs by optimizing the pulsation bottle design. An overly conservative design can have significant cost penalties. When a project includes multiple compressors, the cost penalty of a “conservative design” is multiplied, and directly affects overall capital costs and the packager’s profit.
3. Over the life of a compressor, the field infrastructure may change the operating parameters of the unit (beyond what was anticipated during the initial design). This represents an opportunity to revisit the system design and optimize it where possible. Evaluating the system performance at current and future operating parameters will identify areas to improve capacity, reduce fuel costs, and assess the effectiveness of existing pulsation control devices. Depending on the original design and the degree to which the field parameters have changed, hundreds of

thousands of dollars per year can be saved, even after factoring in the cost of modifying the system.

We term these points of view as “optimized design” efforts as some additional design work is required to determine the optimized solution. The return achieved from an optimized design easily justifies the additional design work.

The first step in optimizing a compressor design is to evaluate the “system performance.” Once the system performance is understood, opportunities for optimization can be investigated.

Please note: The currency referenced throughout this document is US dollars.

## 2 System Performance

System performance includes capacity, efficiency, horsepower (HP), total pressure drop, and pulsations for all intended operating conditions. As shown in Figure 1, the “system” starts with the compressor inlet piping and includes the compressor, piping, vessels, pulsation bottles, orifice plates, scrubbers and coolers. The system typically ends where the discharge piping exits the skid (for performance optimization purposes, modelling on-skid components is usually sufficient).

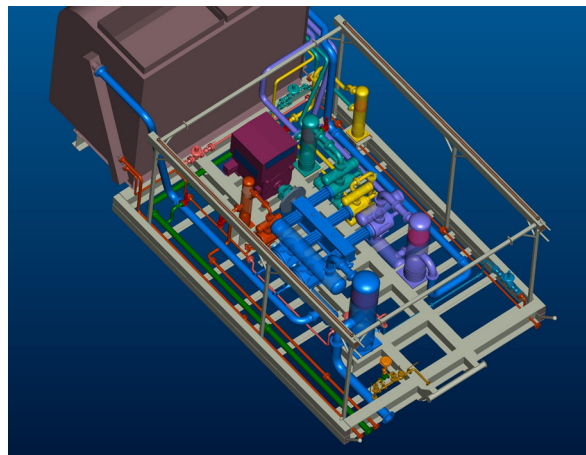

*Figure 1: System performance includes all piping, vessels and pulsation bottles (typically skid edge to skid edge). Illustration courtesy of Exterran.*

The system performance model is available once the proposed compressor design and pulsation solution are complete (see Figure 2). The pulsation solution provides the total static plus dynamic pressure drop results for each stage of the compressor and for each operating condition. Note that the pulsation analysis requires the use of Time Domain algorithms to produce the total pressure drop results. Older style pulsation analysis based on

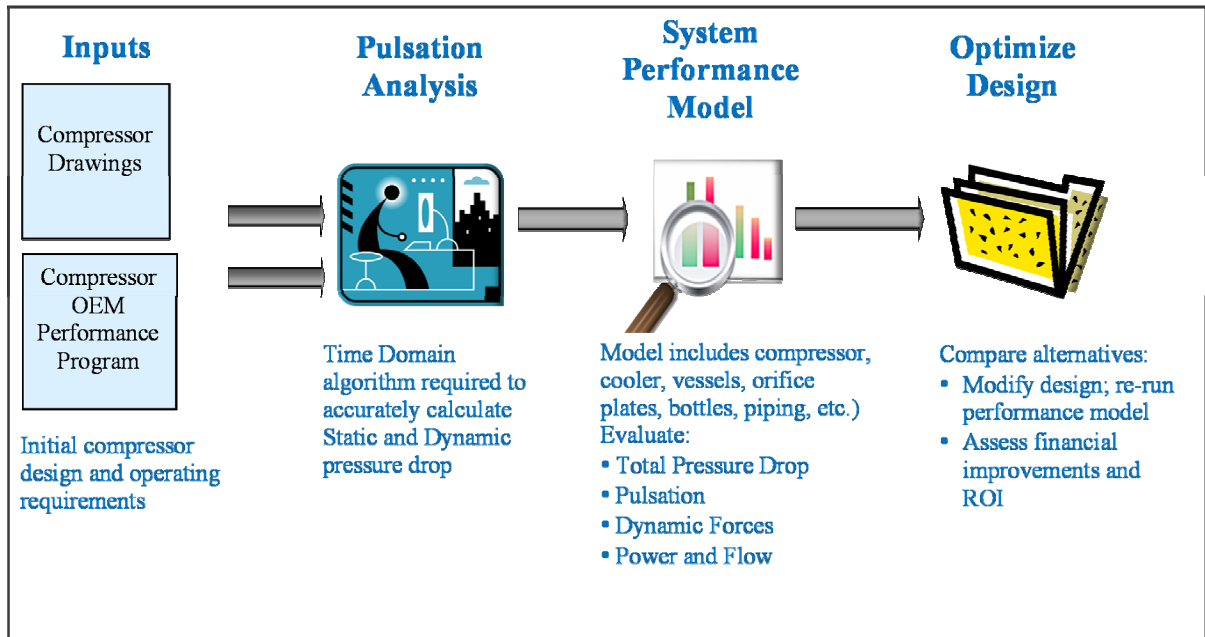

Figure 2: System Performance Model Enables Design Optimization

Frequency Domain algorithms do not accurately model total pressure drop and do not provide comprehensive results for system performance analysis.

The following two examples illustrate the importance of calculating and evaluating system performance models. In each case, the owner expected the compressor would deliver the required capacity based on assumptions used in the OEM performance program. However, the actual system performance is not known until the pulsation solution and final piping configuration is defined. Once the final configuration is defined, total pressure drop through the pulsation control devices, piping, coolers, scrubbers, etc., can be determined for each condition. The compressor performance is then re-evaluated using total system pressure drop (rather than assumed values used in the OEM program) for each condition. In each case the variance between actual system performance and “assumed” performance varies by up to 5% (blue line shown in Figures 3 and 4). This variance can have a significant impact to the owner’s business plan.

- For a 4000 HP unit (single stage), the actual system performance is over \$10 million/yr higher than originally estimated (for conditions 10, 11, 13, 14 and 15). Figure 3 illustrates the variance percent and production value. Incidentally, the variance in fuel gas consumption varies by more than \$160,000 per year.

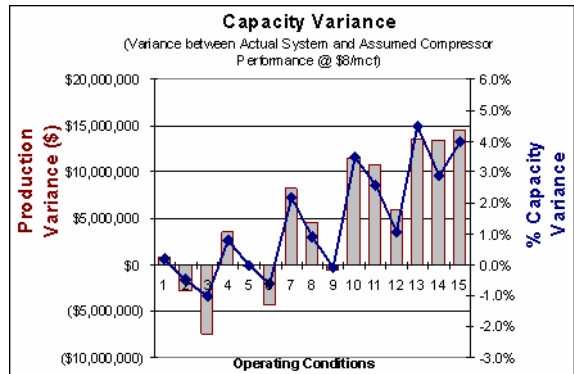

Figure 3: System Performance provides the most accurate picture of overall compressor design characteristics. Example is based on actual compressor installation (6 Throw; 1 Stage Compressor; 4000 HP; 105-245 MMSCFD)

- The second example is a much smaller unit (1600 HP), but in this case the actual system capacity is well below the assumed performance. The negative variance is over \$1million per year for conditions 1 and 2.

These two examples illustrate that variance can be either positive or negative. They also illustrate the importance of an accurate system performance model.

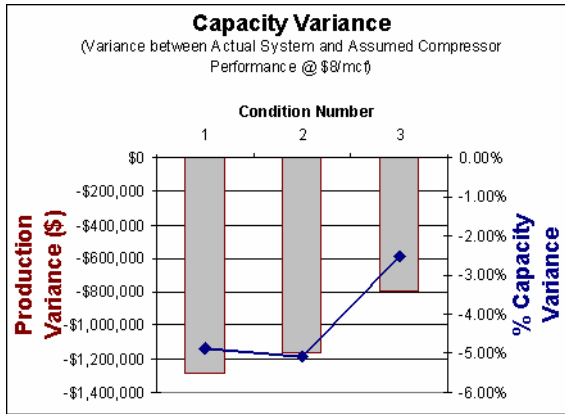

Figure 4: Actual system performance variance compared to planned performance (based on initial OEM performance runs, 1600 HP; 1200 RPM; 4 throw; 3 stage; 7-10MMSCFD; 3 operating conditions).

To optimize the design the recommended approach is to first develop the baseline system performance model. The baseline compressor design can be modified and optimized until a viable solution is found. The pulsation and performance software is rerun to identify the impact of changes in pressure drop and performance. A simple financial analysis of the incremental improvements (capacity and operating costs) is compared to the required capital costs. This process involves teamwork between the owner, packager and pulsation consultant.

### 3 Optimization Examples

#### 3.1 Optimized Pulsation Control Design Increases Capacity

A 1400 HP reciprocating compressor in a gas gathering application was designed for a variety of operating conditions including flow rates between 7 and 19 MMSCFD.

During a field review, it was identified that the unit was experiencing high power losses. The analysis further indicated that the losses would prevent the unit from achieving maximum capacity – a key requirement for the owner.

An optimized pulsation analysis of the existing system identified an alternate approach to controlling pulsations. Modifications were made to bottles to include baffles and a choke tube. With these changes, the losses were reduced significantly. As shown in Figure 5, this optimization reduced HP losses between 90 HP and 150 HP for the key operating conditions under evaluation.

The owner was able to gain significant power by reconfiguring the vessels. The table in Figure 6 outlines the power savings for the key operating conditions.

The annual savings in fuel gas through the improvement is estimated at \$75,000 per year – a reasonable gain.

The more interesting result is that the unit can deliver an additional 1.0 to 2.0 MMSCFD of throughput. Based on the customer’s pricing situation, this translates to over \$3.0 million of incremental production.

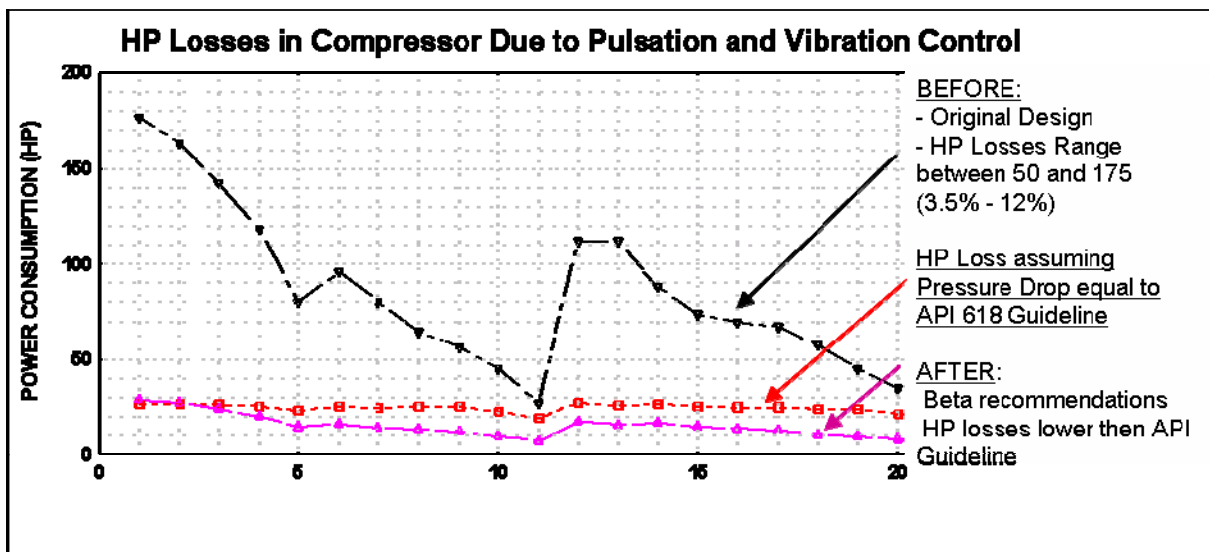

Figure 5: HP losses per condition (before & after)

Operating Condition #	1	2	3	4	12	13
HP Savings	150	137	118	100	95	100
HP/Q Ratio	72	75	83	92	92	92
Incremental Q (Capacity in MMSCFD)	2.08	1.83	1.42	1.09	1.03	1.09
Incremental Revenue (Annual)	\$6.1 million	\$5.3 million	\$4.2 million	\$3.2 million	\$3.0 million	\$3.2 million

Figure 6: Horsepower savings for key operating conditions

### 3.2 Optimized Pulsation Control Design Reduces Capital Cost

During a recent project, an initial pulsation solution recommended conservatively sized bottles for two 6 throw, 3 stage compressors. An alternative pulsation control solution involving smaller pulsation bottles was determined by evaluating the system model. See Figure 7. Smaller bottles were found to be acceptable for both pulsation and pressure drop criteria. The smaller bottle generated over \$100,000 in savings, based on:

- two identical units in the project
- each unit realized \$20,000 reduction in bottle costs; \$20,000 reduction in skid costs (small bottles had a significant impact to the skid design); and approximately \$20,000 reduction in factory overhead.

Many compressors would benefit from an optimized design. For each unit, the hidden capital cost per unit could easily be in the tens of thousands of dollars per package.

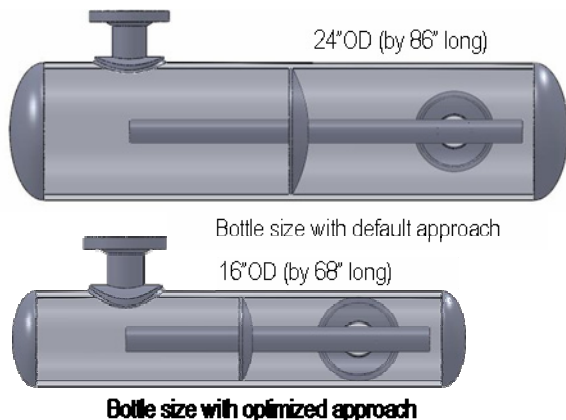

Figure 7: Optimized pulsation bottles saved over \$100,000 for packager

### 3.3 System Performance Analysis Determines Maximum Capacity for Offshore Compressors

The operating parameters for two gas lift compressors located offshore had changed significantly since the units were originally installed. Recognizing that the changes were potentially significant, the owner of the units commissioned a system capacity audit to determine the maximum capacity that could be obtained under the new operating conditions.

Typically the units are assessed using OEM performance software and assumed pressure drops (usually a % of line pressure) to estimate maximum capacity for the new operating parameters. The recommended approach is to use Time Domain pulsation models to calculate the total system pressure drop for all operating conditions and then calculate the performance at the new conditions using the total system pressure drop, rather than assumed pressure drop, to determine the maximum capacity. As shown in Figure 8, the calculated capacity using total system pressure drop was between 5% and 7.5% lower than calculated using typical pressure drop assumptions.

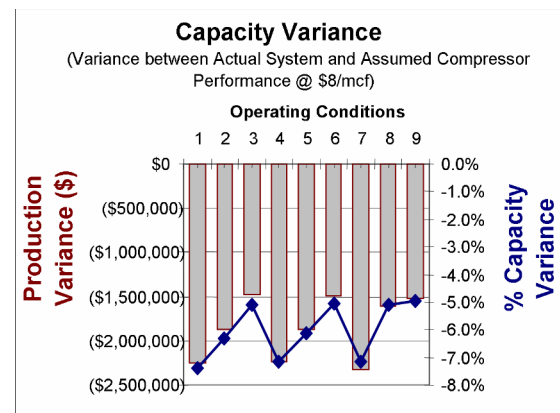

Figure 8: Estimated system pressure drop over predicts capacity

Investigation into the systems identified the suction control valve, several orifice plates and three of the four cooler sections as being the most significant contributors to high total system pressure drop. The pulsation models confirmed that these components could be resized without adversely affecting the pulsation and pulsation-induced unbalanced force levels in the installation. The capacity at the new operating conditions could be improved by between 2% - 4.5% with the redesigned components installed. This additional capacity would generate between \$0.6 and \$1.2 million dollars per year (based on \$8/mcf). See Figure 9. Using this information, the end user can determine the payout

on replacing the suction control valve, orifice plates and cooler sections.

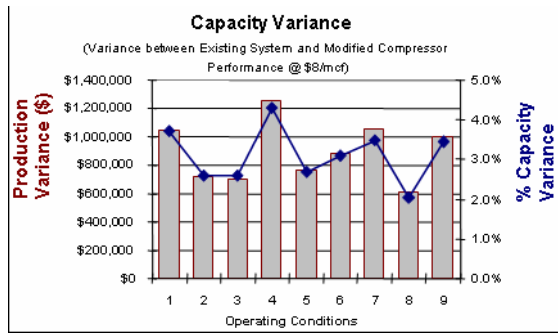

Figure 9: Reducing total system pressure drop increases capacity

While changing the orifice plates and increasing the size of the cooler tubes would reduce the pressure drop of the system, it would be imperative that the driver be fully loaded at all times to achieve the increased throughput rewards. It was recommended that the manually controlled variable volume pockets on the cylinders be replaced with automated load control to achieve maximum capacity.

The capacity audit also identified that the fourth stage compression ratio was low and had a low compression efficiency. Removing the fourth stage would dramatically increase the capacity of the compressor. However, pursuing removal of the fourth stage would create concerns regarding the maximum allowable working pressure (MAWP) of the third interstage equipment. Again, the increased capacity and revenue would have to be weighed against the cost of implementing the changes to determine payout.

## 5 Conclusion

Reciprocating compressors require pulsation control to avoid large dynamic acoustical forces. A pulsation analysis (per API 618) will recommend a pulsation control solution based on the operating conditions, speed range, and other operating factors. Given these different issues, there are many possible solutions – each with a different result in terms of upfront capital and long term operating cost, pulsation reduction, and operating risk. Innovative approaches are available to reduce the total life costs and increase energy conservation while addressing pulsation and vibration concerns.

To optimize the design, the recommended approach is to first develop the baseline system performance model using Time Domain algorithms. The baseline compressor design can then be modified and optimized until a viable solution is found. The pulsation software is rerun to identify the impact of

pressure drop on system performance. A financial analysis of the incremental improvements (capacity and operating costs) is compared to the required capital costs. This process involves teamwork between the owner, packager and pulsation consultant.

Although the new API 618 specification recommends pulsation control should be designed to reduce total life costs and increase energy conservation, design optimization will not normally be pursued as part of a standard pulsation study. It is up to the packager or end user (owner/operator) to specify optimization requirements.

It is also up to the end user to identify when existing equipment may be operating outside the original operating parameters. These changes may introduce additional pressure drop, and create likely candidates for system performance optimization opportunities.

## 6 Acknowledgements

The author wishes to acknowledge the assistance of Brian Howes, Russ Barss, Kelly Eberle, and Jackie Walters, all of Beta Machinery Analysis, in the preparation of this paper.